

radio control MODEL CARS

ISSUE No. 8. Price 50p. \$1.50 (US) DM3.50 Fr. F6 Glr.3.50 SwFr.3.00

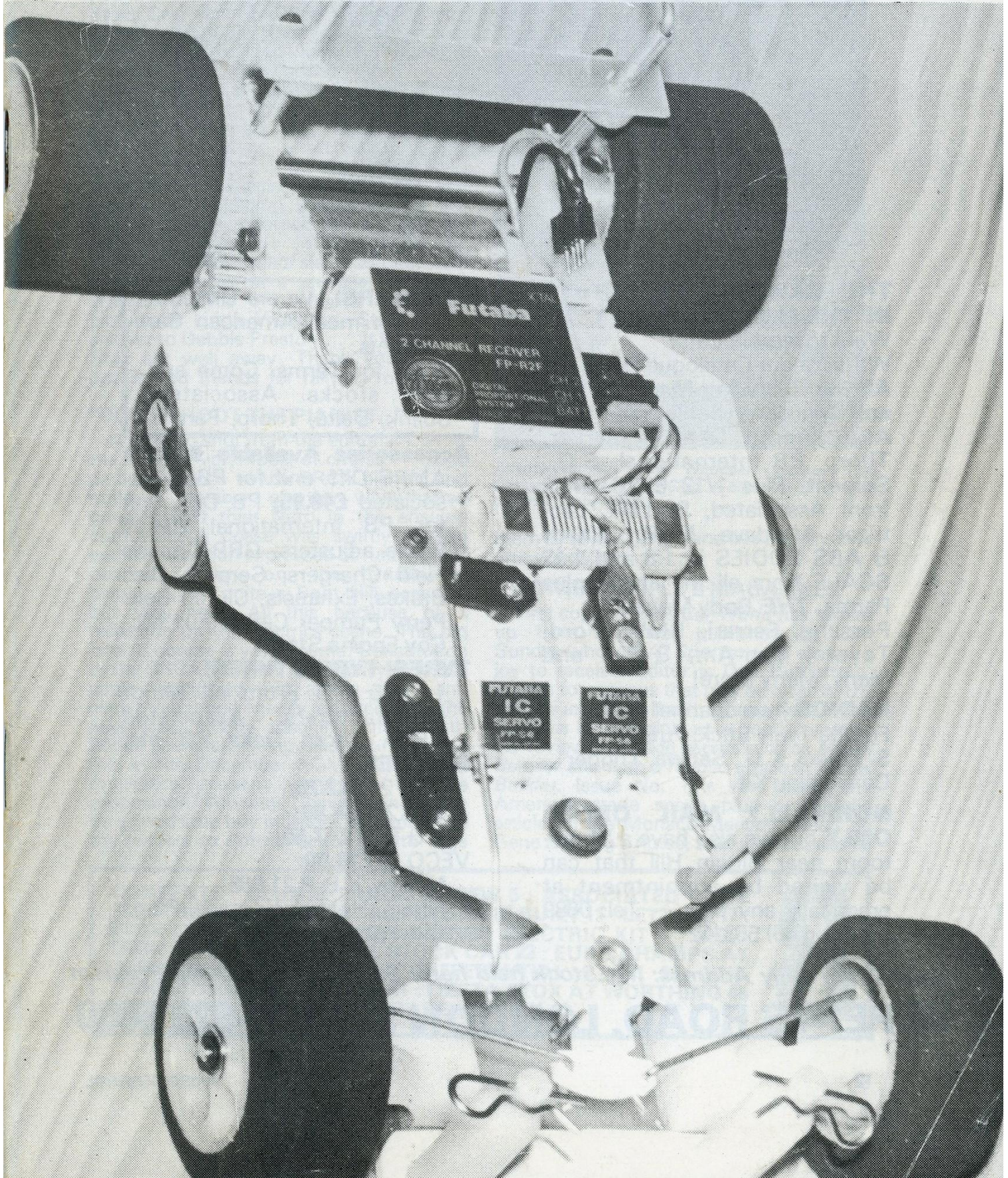

R/C CARS

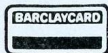

Ted Longshaw



for Service & Experience

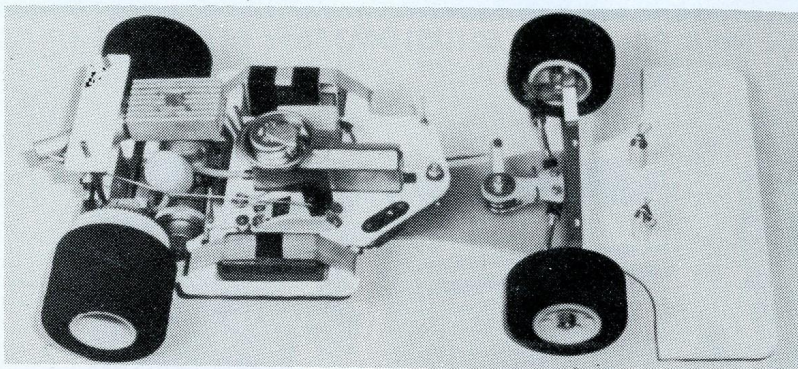

THE LARGEST SELECTION IN THE U.K. Mail Order Only.

Want to start in Cars?

Write for our Catalogue (50p)

All the following Marques Kits and Spares available:

Associated, Delta, Marker, Thorp, PB International, S.G., Serpent, Plus 1/12 ELECTRICS from Associated, Bo-Link, Lectricar, Mardave, MRP, LEXAN & ABS BODIES in 1:8 and 1:12 SCALE from all the above plus Parma, **THE** Body Makers.

Porsche, Ferrari, BMW, Ford, Toyota, Can-Am, & F.1 and Many, Many More!

RADIOS (two channel only)

Futaba Twin-Stick, Futaba S/Wheel, K.O., Sanwa, Trigger Conversion Kit.

NORMALLY MAIL ORDER ONLY but we also have a Show-

room near Biggin Hill that can be visited by appointment at practically any time — Tel: 0689 (London 66) 55313.

Mail Order Only Address: (No stock held here) European Export No Problem

80 PEPYS ROAD, LONDON SE14 01-639 5080

DEALERS! We are Distributors for most American Car Products.

Write for Terms. Come and view stocks. Associated, Bolink, Delta, Thorp, Parma.

Accessories Available include

AMPS Diff. unit for PB & Associated **£49.95**; PB Diff. unit for PB International **£34.00**
Brake adjusters, GRP Chassis Field Chargers; Serpent Disc Brakes, Exhausts, Clutch Bells Perry Pumper Carbs; Full McCoy Engine Stock.

TYRES! TYRES! TYRES!

1:12 & 1:8 From all Major Manufacturers. Associated URFA, Thorp, Delta, PB, etc.

ENGINES:

OPS 21 **£42.75**;

STX21 **£44.60**;

K & B 21 **£47.50**;

VECO 19 **£19.00**;

McCoy/K & B 21 **£85**.

Filters, Heat/sink Heads, Plugs Glow packs, etc., etc.

radio control MODEL CARS

Published by L-D EDITORIAL — TECHNICAL SERVICES LTD., P.O. Box 30, HEMEL HEMPSTEAD, HERTS. HP1 1NL. NOVEMBER 1978.

Editor: "Dickie" Laidlaw-Dickson

STOCK CAR BONANZA

I HAVE been accused of neglecting the Stock Car side of r/c cars — with indeed, some justification. Hardly had this wicked neglect been pointed out than I spent a splendid hot week-end at Worthing to enjoy their very successful Fiesta Meeting, duly reported in this issue. Then along came Alan Hobbs, via Ted Longshaw, with his excellent scratch-built Hobbs Special Stock Car, which also encouraged another of my special interests, more and more scratch building. Last issue's picture of the camera mounted on a stock car brought in Jack Bye with the full story. Need I add that I have also had one more and the promise of a series of stock car articles . . . Plus of course a very nice picture of Linda Woodger, Stock Car's answer to Debbie Preston . . . It looks as if Stox are well away. Thank you contributors and friends for rallying round.

"DON'T SHOOT THE PIANIST..."

A ranging shot from the editorial Colt — the new 7.2 volt model of course — came perilously close to the BRCA pianist, and quite a number of the white-hatted goodies spilt their Nitro in the ensuing confusion. A posse was swiftly formed and the intention expressed of running self out of town on the traditional plank . . . not quite a Boot Hill occasion but very near. All this because of a reflection on the electrics scene. The big joke of course is yet to come. Constitution of the BRCA is limited specifically to 1/8th scale racing, so that action taken and even more urged equally incorrectly by the mag was, strictly speaking, unconstitutional! Steps are being taken to regularise this at the December AGM. What if the members present vote against the proposition? Anyway, I have been told to be a good little boy in future and not incite the readers to riotous action but to urge



Twenty-year-old Linda Woodger, secretary of Chessington Radio Car Club. A blue top driver and member since 1977.

them all to join BRCA and live happily ever afterwards.

OTHER PEOPLE'S MAGAZINES

First copy of *Race Car World* has turned up from America, published by Jim Sunday whose *R/C Sportsman* is always a joy to receive. Editor is Dan Rutherford, known for reasons that may be clear to US readers as "Dirty Dan", whose forte in the past has been mainly as a good commercial reviewer in trade papers such as *Model Retailer* and with a regular article in *Model Builder*. Issue No. 1 is very much the American trade scene plus a splendid article on the Monaco Meeting based on Gene Husting's notes, best summarised as

CONTENTS : CLUB & TRACK REVIEW 5 : ASSOCIATED RC12E ELECTRIC KIT REVIEW 8 : SG FUTURA III BUILT 11 : LETTERS 17 : STOX ON MAGPIE 19 : NEW BRITISH ELECTRIC KIT — SPECTRON 20 : HOBBS SPECIAL STOCK CAR 22 : EURO CHAMPS AT LILFORD 30 : SOMETHING DIFFERENTIAL PT III 36 : INTRODUCTION TO CASTING 41 : FIESTA STOX AT WORTHING 45 : SHOPPING AROUND — TRADE REVIEW 49.

8

"how the Americans didn't win" — a very frank analysis of shortcomings that will undoubtedly be overcome by hook or by crook before Geneva next July. Format is broadsheet on newsprint and Web offset printing but some pages very good reproduction.

From time to time I hear in long transatlantic phone calls from Larry Hubbert Jr who is still pressing on with efforts to restart his **Racing Circuits**. He tells me he has now acquired his own printing equipment and issues are only just round the corner. Advance copy of first re-issue arrived by airmail, mainly reports of Euro-Champs (my report) and U.S. Nats, always a revelation. Just on the horizon, too, is the improved *Circuit Chatter* promised in latest newsletter. Quality of German, French, Belgian, Dutch newsletters has outstripped CC and a revised improved issue will certainly be welcome.

There are also a number of promising club newsletters coming along including *Wheel Spiel* from London, the ever-mentioned *Ally Pally Newsletter* with its excellent Snoopy style cartoon heading each issue, and the excellent *Radio Stock Car Association Newsletter* which Wes Raynor took on his already heavily burdened shoulders at the last AGM.

THE EUROPEAN CIRCUS

Just as the fullsize racing car world and even more so the motorcycle racing world have their chain of circuits involving an almost continuous suitcase life, so the model car fraternity seem to be chasing from country to country putting on a show. The well-known circuit team of Plested-Greeno-Longshaw has been having so successful a tour that it would be news to learn that someone had actually beaten them! List of battle honours for the PB International reads like an International Fixture List. So the news that Ronnie Ton had cleaned up the Benelux Championship with his SG comes as something of a change. Ronnie travels in what must surely be the most comfortable of all ways, with his spacious

caravan (and workshop), wife to comfort, sustain and cook meals, children to support dad and run any useful errands and hold the other end of the car. I noticed at the Euro Champs that some of the other continentals were very nearly up to Ronnie Ton standards of comfort with car-a-vans or "living lorries" and supplementary tents, though nothing yet to equal the enormous Mercedes lorry at the Lyons meeting in '77 that even carried a motor cycle on the back as a shopping vehicle.

Last thought on this must be to commiserate with the laddie from Scotland whose tent was literally flooded several inches deep at Lilford Park — he was hosted by a kind friend with a spare van floor . . .

THIS ISSUE . . .

This issue deliberately comes out well into November so that it can legitimately call itself a Christmas Number. So "Happy Christmas" everybody. It will therefore still be current right up to the end of the year, when hopefully any copies left over can be flogged at the **Model Engineer** Exhibition at Wembley. Not that there are likely to be many overs if current trend continues, so desirably so, an extra lot will be printed to cope with that expected demand . . . and so to thoughts of the next "M.E. Ex" . . .

MODEL ENGINEER EXHIBITION

Opens January 4th and runs to 13th (but not on the Sunday this year!) at the Wembley Conference Centre. Should be more model spaces this year as Woodworker Show will be a separate function and of course our old friends of last year will be there, Ted Longshaw and Phil Greeno with host of goodies to sell, advice to give, and friends old and new to be met and made. Roger Wilding of Modelcraft will also be setting up his stand with the widest possible selection of Mardave items which is very much his speciality. I hear on reliable authority that electric car racing will not, as last year, be taking place in a large parrot cage but will have a decent sporting circuit which if smallish will still provide an excellent testing ground for cars — see the latest MAP publications, especially the Exhibition Extra Model Engineer for details.

Hopefully there will be more cars entered this time, and they will have a better crack of the whip displaywise. I have been invited to judge this section, tempted by a free lunch, and look forward to seeing some interesting scratch builds. Entry date will have passed by this issue so hope you have already done your stuff.

IN THE NEXT ISSUE . . . DELTA SUPER-J BUILT : FUTURA III TRACK/RADIO TESTING : NEW SERIES ON TYRES : STOCKCAR "WORLD" CHAMPS : LATE SEASON MEETINGS : NEW ELECTRICS : CLUB AND TRACK REVIEW : LETTERS : SHOPPING AROUND — TRADE REVIEW :

CLUB & TRACK REVIEW

Strathclyde Model Auto Club

Secretary: John Wilkes,
73 Almond Road,
Abronhill, Tel. Cumbernauld 31518.
Cumbernauld, Glasgow G67.

Please note change of secretary, new address and telephone number. The club would like to thank Mike Green who held this post from the start of the club. Big news is that the club is changing over to 1/12th scale electric, with the main rules: 6 cells, RS54 motor, or equivalent, as fitted to Mardave and Lectricar kits. There has been some feeling that with 1/8th scale there is the danger of costs mounting in a spend and go faster spiral such as bedevilled slot car racing. New members and interested parties welcome.

The Gladiator Model Car Club (Oxford)

Secretary: Alec Hudson,
2 York Close,
Bicester, Oxon. Tel. Bicester 45601.

The club has a permanent slot car circuit, and has now extended its activities to r/c 1/12th scale electric cars. Sunday mornings are informal at present, but club racing will start in November, the small circuit being indoors on a wooden floor. There is every possibility of a larger outdoor venue being available before the end of the year. This would be smooth tarmac with flood lighting. The secretary can be contacted during working hours at Howes Model Shop (Tel. Oxford 42407).

Roarin' 20s Model Car Club

Secretary: C. J. Woolf,
7 Wheel Leisure Close,
Perranporth,
Cornwall. TR6 0EY.

Secretary Woolf writes: "On behalf of the club I would like to express my thanks for the very useful letter you sent giving hints and tips on finding a suitable circuit for our model cars." The club now has a suitable site, namely a car park belonging to a cash and carry warehouse. Still very much a fledgling club they are taking time to settle down but enthusiasm is winning through. At the moment they are running the standard combination of Mardave F/1 with Veco 19, with two exceptions — a PB Dual and Mardave with an Austro-Webra engine. New members very eagerly sought — the excellent racing facilities should encourage as Secretary puts "some of the more exotic machinery to make an appearance." The club claims to be the furthest West as yet.

WITH 1978 Racing Season finished, and meetings with points now counting towards the 1979 Season, clubs are looking carefully into Racing Calendar arrangements due to be finalised, hopefully, at the AGM in early December. The pattern this year has been for the "aces" to go trophy hunting across Europe over the first weekend in each month, when a National Event is usually scheduled. Their visits have not gone unrewarded . . . to an extent indeed that PB International is almost the dictionary expression for a model racing car, like Hoover, Kodak and other product words! One other benefit, this time for the stay-at-home drivers is that these early in the month home meetings without some of the experts provide opportunities for the up and coming to come up that much sooner.

With so many new clubs starting up and others attaining the status of purpose-built circuits the compilation of an equitable fixture list becomes more of a problem and puzzle than ever. One useful variation we have heard mentioned is to develop local inter-club meetings one day a month, when heats are run with a car from each participating club on the start line, rather like speedway meetings. In the fairly farflung West Country this should solve the time and cost of travelling to the more distant events — we could have Bournemouth, Mendip, Bristol, Torquay, Taunton, Exmouth, making a formidable local league, and able to give less expert drivers a chance of running against other clubs inexpensively.

Also to be decided will be the date and venue of 1979 Nats — not we trust chosen to clash with an important Continental event again. We understand Mendip will be putting in a keen bid, with Wombwell asking for a repeat and who knows what else. London we believe would like the British G.P. date. We shall know it all at Swindon on December 3rd.

Skyryders Model Club (R/C Car Section)

Secretary: (Cars): J. Nicholls,
115 St. Edmunds Walk,
Wootton, Isle of Wight. Tel. 883 120.

Racing takes place fortnightly, running 1/8th scale cars. The car section is just getting on its feet, currently running a series of races for a club challenge shield. Club is based at Puckpool, Ryde on the Island. New members would be welcomed, enquiries as above.

Truro & District Model Car Club

Secretary: Dave Wellington,
9 Polwhele Road,
Truro,
Cornwall. TR1 1RF.

This is another new West Country Club with ten members and a great deal of interest. At the moment club circuit is on an abandoned airfield (very bad surface) and there is a keen look out for a more permanent track. So far efforts to obtain use of car parks have been unsuccessful, the usual brush-off given that it must go before the local authority. Let them try the tactics that usually succeed namely: (1) Approach local newspaper and arrange demonstration on their present horrible ground. (2) Talk to their local councillors — what is called "lobbying". (3) Approach any local youth organisation to gain their interest. (4) Chat up their local MP and stress the value of the club as a "youth organisation" — keep the lads out of mischief, etc. (5) Speak to local school headmasters and interest them in the metal working aspect of the hobby. If this doesn't succeed do all over again — with enthusiasm and skins like elephants you can't fail to make it!

South London Smoothies

Secretary: Richard Gammon,
46 Church Road,
Barnes SW13. Tel. 01 741 0333.

Another way out club name for you! This is based very much on the enthusiasm of Richard Gammon (of Smoothie fame) and Wendy Bork who have sought out a splendid medium sized hall with clean wooden floor — not ballroom slippery but quite tricky — in the Tulse Hill area to provide a South London venue for electric car racing. Racing normally takes place on Monday nights from 7.30 to 11pm, there is usually a bar open for drinks after racing, and there are some of the hard to get goodies on sale for the scratchbuilder. Racing costs £1 a meeting, and interested parties should telephone Richard to confirm meeting and get details of venue. Note: Silicon coated tyres recommended. So far club members have not been undistinguished — Teamtronic with Richard, Wendy and Derek Scott were 5th (best London placing) in the recent Blackpool Illuminations Meeting 3-hour team race.

Swindon Electric Car Club

Secretary: Jan Korda,
Swindon Model Centre,
2 Theatre Square,
Swindon, Wilts. Tel. Swindon 26878.

This is another new electric car club,

with Jan Korda of Swindon Model Centre acting as the founding secretary. Now about three months old it is a dozen members strong, and growing all the time. Most members do both i.c. and electrics. At the moment the search is on for permanent facilities both indoor and outdoor sites, though the club has use of two halls. New members very welcome, apply as above.

Woodspring Radio Auto Club

Secretary: R. Beckett,
GB Models,
9 Thornbury Road, Uphill,
Weston super Mare.

Secretary Richard Beckett reminds would-be entrants that the Mendip Circuit hopes to continue active during the winter months and that their next exciting event will take place on Monday, January 1st — which is a public holiday nowadays in case anyone had forgotten — with a Formula 1 event; get in touch with Richard to obtain latest information, times, entry fees and so on. There have been considerable additions and improvements to the circuit during the summer including, as mentioned before, an end to the stony path encountered by drivers straying off the straight!

Chessington Radio Car Club

Secretary: Linda Woodger,
1 Newton Close,
Langley,
Slough, Berks.

That energetic Chessington Club has provided a summary of their year's activities. While not wanting to pat them too hard on the back their approach is one that many clubs could emulate with advantage. Well done Chessington . . . now the story (somewhat abridged). Secretary Linda, the club's only lady stockcar driver, has not only introduced a regular newsletter, but also presented the club with a challenge trophy award for a series of meetings. Race meetings have been held almost fortnightly, and some members have travelled round to other RSCA clubs at Worthing, Haywards Heath, Leicester and Coventry, while two enthusiasts made it as far as Keighley in Yorkshire! The club's publicity campaign has worked well. Thames TV presented the club in action on Magpie (see Jack Bye's "How we did it" feature) and attendances at school and church fetes, charity organisations (in particular the Imperial Cancer Research Fund) have raised funds for good causes and been much appreciated. Membership has risen from a figure of 35 members at the beginning of the year to a current membership of nearly ninety.



PHIL GREENO

MODELS
LIMITED

9 Village Way East, Rayners Lane, Harrow, Middx. Tel. 01-8667770

"THE WINNING COMBINATION"

A limited number of Phil Greeno Monaco Replica cars are now available ready made and ready to race less radio and engine. Each car includes:— G.R.P. chassis, A.M.P.S. differential unit, Delta steering, flip top tank, roll bar, brake adjuster, racing clutch, engine mounts, aerial, alum. body post, wheel/tyres, silencer, all linkages, Lexan body of your choice **£250.00**

SPECIAL ITEMS

G.R.P. Chassis	£8.50
Brake Adjuster	£3.95
Roll Bar	£2.50
Alum. Body Post	£1.65
Comp. Clutch Nut (P.B.)	£2.50
Flip Top Tank	£12.95
Pumper 61 Carb.	£7.95
SG. Air Filter	£1.95
P.B. Air Filter	£1.50
Delta Fuel Filters	£1.65
Delta Output Arm	£1.25
Assoc. Fliptop CID	£3.95
Field Charger	£7.95
Glowpack	£14.95

Veco/McCoy parts always in stock

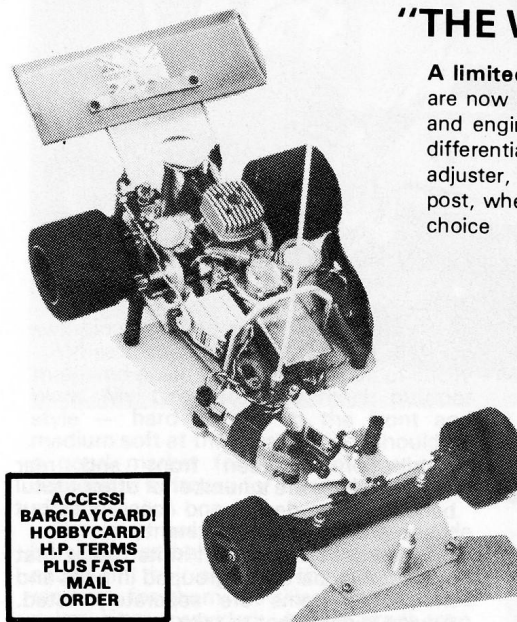

ACCESS!
BARCLAYCARD!
HOBBYCARD!
H.P. TERMS
PLUS FAST
MAIL
ORDER

R.C. CARS

	£	p
P.B. International.	75.00	
P.B. Expert Comp	61.38	
P.B. Expert STD	45.04	
P.B. Dual	29.18	
S.G. Comp.	66.72	
Futura 3.	72.00	
Associated RC200	105.00	
Associated RC1	59.90	
Latest Delta 780 Super J .	105.00	
Mardave Formula.	23.75	
Mardave Saloon	23.75	
Mardave Stock car.	23.75	
Ke'jon Stock car	29.50	

PLUS A large stock of R.C. car spares always in stock including P.B. Associated, S.G., etc.

All prices correct at time of going to press but subject to alteration.

ENGINES

O.P.S. 21 Car	£42.95
ST. x 21 Car	£44.57
K & B 21 R/C	£47.50
Veco 19 R/C	£25.95
New Veco 21 R/C	£28.95

Irvine 21 R/C **£29.95**

NEW! M.R.P.

Jerobee r/c electric, £55.95.
Lectricar with prop. speed control . . **£44.87**

Also large stock of BO-LINK, JOMAC, JEROBEE, ELECTRO CRAFT 1/12th ELECTRIC CAR KITS AND ACCESSORIES

JUST ARRIVED

New A.M.P.S. Differential Unit with bearing blocks and disc unit to fit P.B. International **£49.95**

REWORKED MOTORS

Inc. Pumper Carb.	
O.P.S. 21	£65.00
ST. x 21	£65.00
K & P 21	£69.95

Plus parts available separately.

specialists in **SKYLEADER FUTABA SANWA MacGREGOR**

Opening hours: Mon., Tues., Thurs. 9.30-6.00 Fri., Sat. 9-7.00. Closed all day Wed.

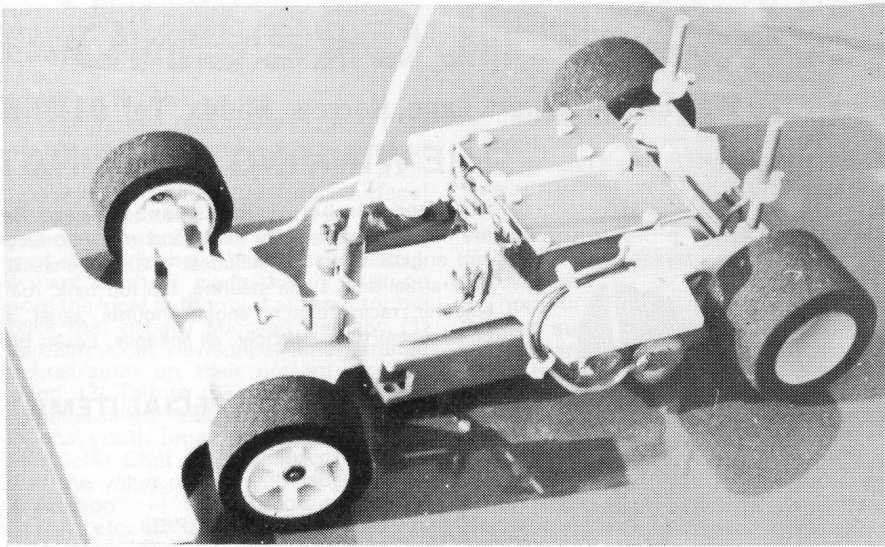

ASSOCIATED RC 12E 1/12 ELECTRIC

MY extravagant friend 'phoned from America: "What do you think? Those Associated people have cleaned up again; this time they've done it with the U.S. Electrics Nationals!" Details sadly lacking at £2 a minute but that is the gist of it. I loved the prototype seen at the German Toy Fair earlier in the year, now I have managed to get hold of one of the first batch of six coming into the country to make up and write about, and have no reason to revise my earlier opinion that it is something very special.

Gene Husting does not really do justice to it in his introduction when he says it is "not a converted gas car." To the extent that it is not a production power chassis put to another use he is correct, but, in fact, he has used the company's know-how to make up a little car that enjoys all the design features of the 1/8th scale range scaled down to 1/12th. Let's just recap some of the special points: GRP chassis, radio tray, light weight, mid-engine design — that is engine is forward of rear axle — to bring better weight

distribution between front and rear wheels. There are a number of other useful benefits in the design and accessories but these are the most pertinent.

Presentation of the kit in its box is first class. Small parts are grouped in bags and the larger items are separately listed. Advice is given not to take small parts out of the bags regardless. We checked ours carefully and after removing the staples refastened with sellotape until used. Touches like this are very welcome; as was one of my principal sources of aggro — there was a far more than adequate supply of what they call "E-clips" over there or circlips to us. I could actually lose one or two safely! Instructions for kit assembly are amongst the most comprehensive I have yet to read, so that there is very little that need be said on the step-by-step procedure.

Servo saver is simple, ingenious and practical with a good exploded drawing to make sure bits are put together in the right order. Very nice nylon steering blocks with very little flash to remove. Steering tie-rods follow the rather awkward practice of being just bent wire — a couple of cranks one at each end. Drawing shows them thus, so does the handout photograph, but I note that picture on the box goes one better with the introduction of the little grub screwed metal blocks used to adjust brakes, throttle etc., on 1/8th scale. I have used the plastic retainers that come on a little tree of about a dozen from Micromold. This makes a really free

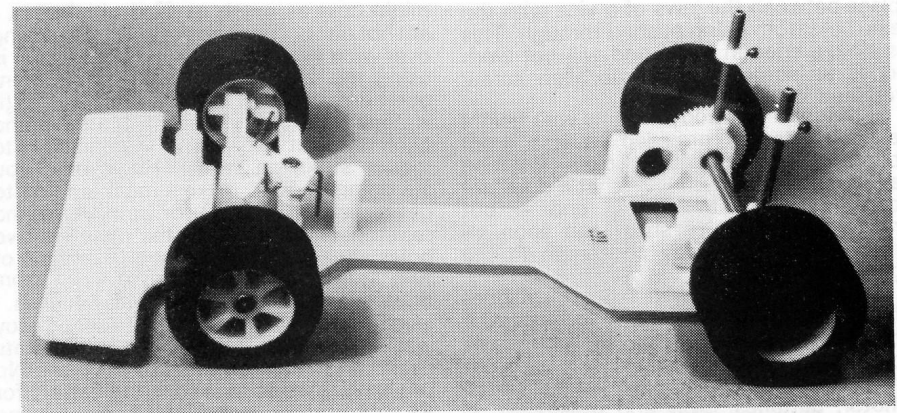

swinging steering unit come easily.

Wheels on nylon hubs by the way are trued and glued, saving quite a bit of sticky work. My tyres are very much outdoor style — hard as iron at the front and medium soft at the rear so there should be a good market for some of the other degrees of softness for the coming winter sessions.

Provision has been made on rear axle brackets for ball bearings if required as extras. In their absence the ready bored recesses for them are filled with suitable nylon rings provided. An up-grade can thus be made at any time without much trouble. Engine location allows sufficient movement of motor to enable a variety of gears to be fitted. Novelty, the small motor gear is a drive fit and must be pressed into

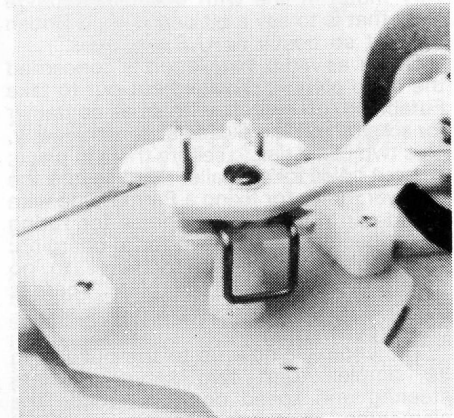

Car on the cover is the Associated RC12E in prototype form.

Heading shows Phil Green's car with Nick Adams' Speed Controller (very neat) single servo, and Rx slung under radio plate.

GRP chassis assembled showing forward engine location.

Detail of servo saver showing arrangement of simple spring.

Two servos in place, with "Parma" type speed control resistor wiped by servo arm. Note track rods fitted with grubscrewed retainers.

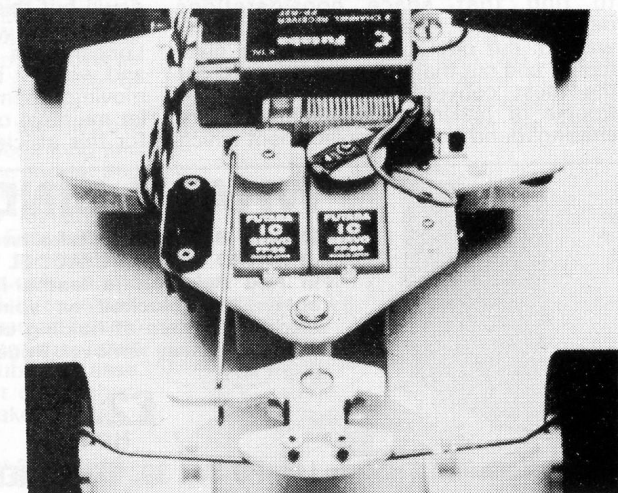

place between the jaws of a vice with the axle held from being pushed through. This is simple enough to do and will not work loose as some of the grub/allen screw retained gears do.

Front and rear body mounts with height adjustments are provided as is a front bumper. You may find as I did — wanting a Renault F/1 bodyshell — that it does not conform to the body front end — but never mind a bit of sheet can soon be made to suit; or body chosen to fit the goods provided.

The kit as offered in basic form goes further than many U.S. kits in that a complete box of bits for the chassis is provided without need to add supplementaries. That is to say the car lacks motor, batteries, body and radio gear. If these are added to cost of the kit it comes very much in line with the middle range cars, that is to say a bit dearer than British but not so costly as U.S. "exotics."

So far as radio installation is concerned the radio plate is provided cut out to take Futaba on/off switch, with small container for six side by side nicads across the body, plus two cable ties to secure them in place; cut-out holes for a smaller tie to secure the receiver; holes for fixing a Parma-type wire speed-controller resistor; holes for fitting an unspecified jack socket for re-charging; and a big hole for sundry wires to go through to under the radio plate. There is also a simple stylised diagram of 4 and 6-cell circuits.

The choice is now up to the builder. In its simpler form two servos operate steering and speed control. I made the elementary mistake of cutting out my radio plate to take two 17M Futabas only to find that space considerations demanded the smaller 16 type. So be warned: cut out a thin card radio plate replica and cut that out for size first to get the most convenient layout and save trouble of making a new plate and/or chasing round to buy a replacement which

might cost as much as £2 if obtainable. I am not altogether sure that I like the swing over wipe on the wirewound core which is using the servo as the actual instrument operating with the attached wiper arm (it is done of course with both Mardave and Lectricar, but with some modification to reduce strain on servo). However if you are going to do it, make a mock-up first to get the exact position for both servo and resistor. This is fixed to the plate via two holes already drilled thereon by means of two little angled brackets bent up from tinplate or dural and slotted into the ends. I also made up a couple of deep alloy washers to keep it well clear of the plate itself and act as mini-heatsinks. No provision is made for a separate battery for Rx, the more useful and weightsaving method of tapping into the main nicad pack is to be preferred. Bold people can do it just like that, with a common negative lead. Others will prefer to wire in a voltage regulator to save them from themselves.

A lot of drivers will opt for an electronic speed controller to do away with one servo. This can be either Smoothtronic, Electrocraft (and its British derivatives as per Nick Adams) or the latest Viking. Electrocraft, by the way, are now advertising an additional gimmick to give full reverse whilst Viking will be having this on theirs soon if not already available by the time this appears. Fitting of this offers a problem or two. Smoothtronic is the easiest to fit, set side up with the wires showing, it can be secured with a U-shaped bracket screwed to radio plate to keep it just clear of the GRP chassis. This looks less tidy than having it wiring side down but this would involve some space difficulties with smaller bodies. Ted Longshaw is the main British distributor and word or letter to him will get things moving. Thanks, by the way, to Ted who let me have one of the precious few kits for this article.

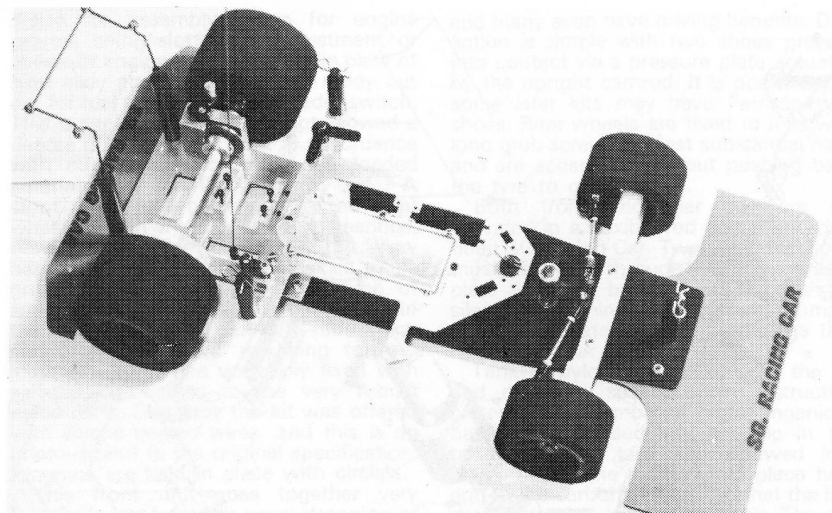

FUTURA III THE LATEST FROM ITALY BY "SABO"

FRANCO SABATTINI, driver-proprietor-designer of the SG range of r/c racing cars is happy in a very close association with neighbouring model engine firm of Super Tigre, indeed the G of SG is for Garafoli, the family making the engines. So one rather tends to think of his cars and the engines as going together like pork and beans and naturally the review of his latest Futura III kit includes the installation of a Super Tigre X21 . . . though not alas as yet the latest as used in the Euro Champs this summer. Futura III was very much the darling of a car-oriented German Toy Fair this year and is the result of a number of year's steady development.

Here at last is very nearly the ultimate Sabattini produce, destined for a long and successful run, rather than the shorter and changing kits that have gone before. In this well-developed form a lot of new departures should be noted. First to strike the builder is that, contrary to the usual custom of Italian language only, or no instructions at all, Futura III is so amply provided that a clever Chinese or Eskimo with no knowledge of the language, could make up a car in almost troublefree ease. The answer? Quite the most comprehensive set of photo how-to-make pictures I

have seen, in total 187 progress photos on the main instruction sheet, plus 22 more on tank assembly, plus two large exploded drawings. Only possible criticism of this splendid collection is that in a new edition it would help to number them, as sometimes the next step is a little hard to find. There are no words — just the pictures.

It may seem a little pointless therefore to write a constructional feature, so that what follows is strictly factual and intended to add to the pictorial account.

First of all the chassis is in two parts, a substantial engine base 4mm thick to which is attached a black anodised alloy main plate 2mm thick. Both are ready



The basic kit assembled. It includes the plastic fuel tank and the stout adjustable track rods, as well as disc brake, antenna & clutch parts, shown on right.

WHAT A BIND !

Elegant BINDERS to take twelve copies (two year run) of RADIO CONTROL MODEL CARS now ready. Covered in Red Balacron (a leather-like material) with "gold" colour title blocked on spine they have the famous Easibind system of holding copies without damage and permitting easy removal. Price includes postage, packing and VAT.

£2.75
HOME

£3.25
OVERSEAS

Sent direct by Easibind. Allow 2/3 weeks for delivery

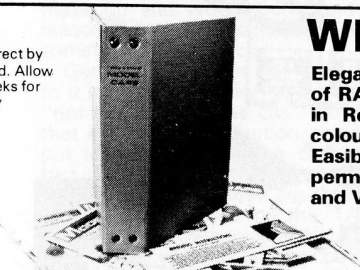

L-D Editorial & Technical Services Ltd. PO Box 30. HEMEL HEMPSTEAD, Herts. HP1 1NL

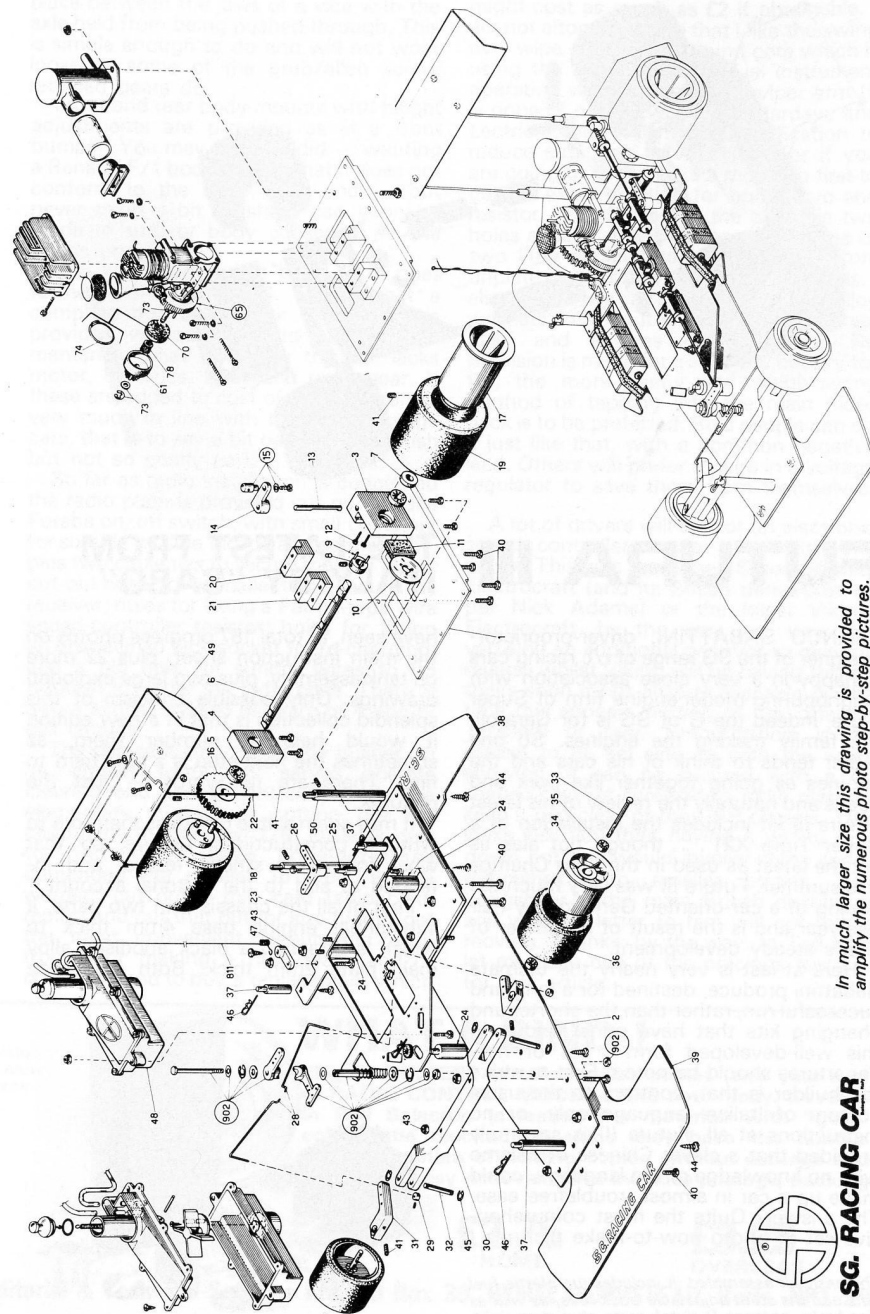

In much larger size this drawing is provided to amplify the numerous photo step-by-step pictures.



drilled for assembly, holes for engine bearers being slotted for adjustment or choice of engine. A separate radio plate of hard alloy about 1½mm thick ready cut out for fuel tank, servos and radio switch. This is anchored at the rear but allowed a degree of float at the front in accordance with current practice. A spring loaded antenna wire and fixing is provided. A stout nylon axle beam carries the front wheels, which are fitted with ballbearings, now shielded against dust and dirt. Very neat nylon axle blocks allow axles to be grubscrewed into place. Usual type of springloaded servo saver is connected to the axle blocks with stout track rods which screw into ball joint moulding for adjustment. These are unusually fixed with self-tapping screws to the very robust nylon parts. Originally the kit was offered with simple angled wires, and this is an improvement to the original specification. Kingpins are held in place with circlips.

This front unit goes together very happily (apart from my usual dropping of circlips!) and the wheels spin very happily with a minimum of effort.

At the rear stout ballraced axle hangers house the massive alloy axle which combines strength and bulk without weight. Contrary to some cars the disc brake assembly is on the left (looking forwards) separate from the driving wheel and gear on the right. I think this separation makes for a neater assembly

and many even have driving benefits. Disc action is simple with two shoes pressed into contact via a pressure plate actuated by the upright camrod. It is possible that some later kits may have Ferrodo type shoes. Rear wheels are fixed to axle with long grub screws against substantial flats, and are accessible without pushing back the tyre to get at them.

Both front and rear bumpers are provided in a flexible red compound duly titled SG Racing Car. Two additional holes must be drilled through rear engine base plate and rear bumper to take the SG silencer retaining bolts. Rear bumper screws also retain the nylon bearers that house the rear wing support.

Tank of nylon is supplied with the kit and merits a special short instruction pictorial for assembly. A highly ingenious baffle X is pressed into a sump in the bottom of the tank and screwed into place. A fuel line is fitted into place here and to the carburettor lead so that the last drop is used to leave a dry tank. The top section of the tank has a tall filler tube on top, with a spring loaded rubber ringed filler cap, with drip tray beneath. A suitable connection for both carb and silencer pressure line is embodied in the moulded top. A further fine rubber ring encircles the

Almost ready to go with MRC radio gear and servos installed, ST X21 fitted and SG silencer. Spare hole on radio plate is for the "other" rx. on/off switch if used.

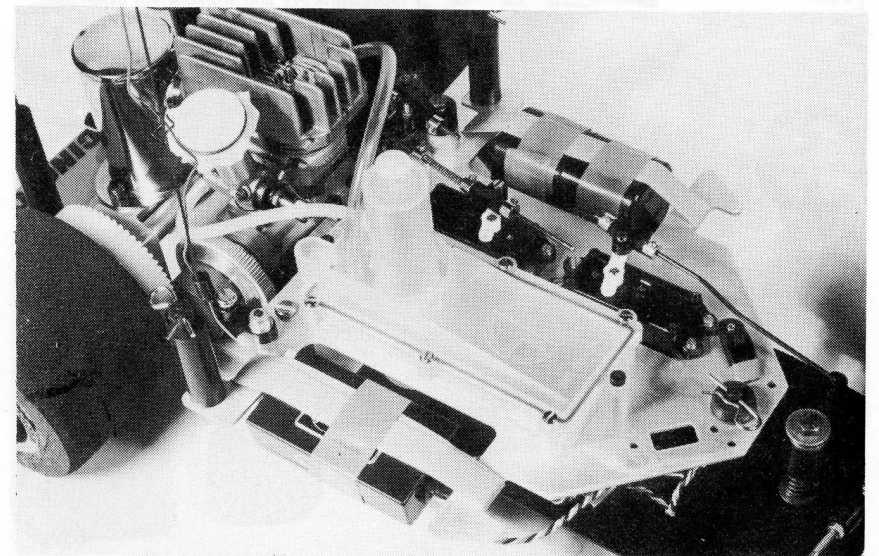

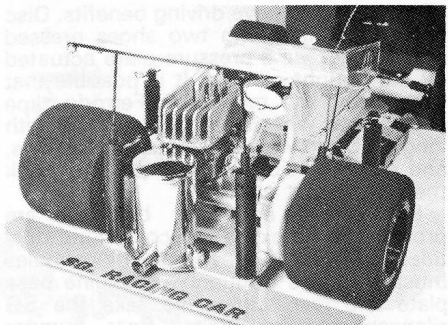

Rear end showing the silencer in place (drill your own holes) and also air filter — again SG.

Below: Brass fuel tank available as an extra if so desired. Both types plastic and brass enjoy the springloaded filler.

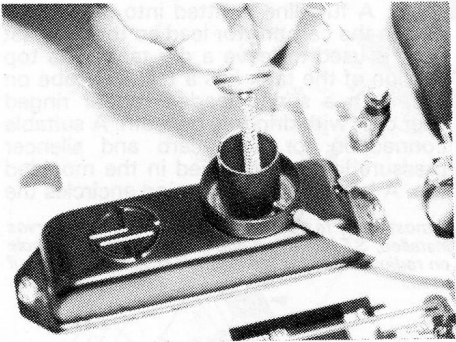

top section which is screwed down into the lower part making a positive seal. Two further long bolts secure it in place in this custom built hole on the radio plate. A similar brass fuel tank is available as an extra option and has been seen around quite a lot this season, but should not be necessary — only a luxury!

Super Tigre fits easily into its designed place with the usual SG clutch unit which has an encircling ring to hold in the two shoes. These are now further improved by a metal strengthening casing which should effectively prevent any disintegration at speed, though we have not heard of this as a very usual problem. Alloy air filter with silk covering is the usual ploy, but SG are also offering a larger and neater plastic air filter with a much closer mesh plastic air filter with a much closer mesh plastic air filter with a much closer mesh plastic air filter with a much closer mesh plastic air filter.

Radio installation gives an opportunity of installing the MRC equipment which MRC (UK) Ltd in the person of Jack Williams have generously made available. As the issue goes to press the car is ready for test and I hope that some of the London R/C Club SG enthusiasts will help me in giving it a track test to be reported hopefully in our next issue.

This shows the whole car with Tx in background — a most attractive and workmanlike assembly.

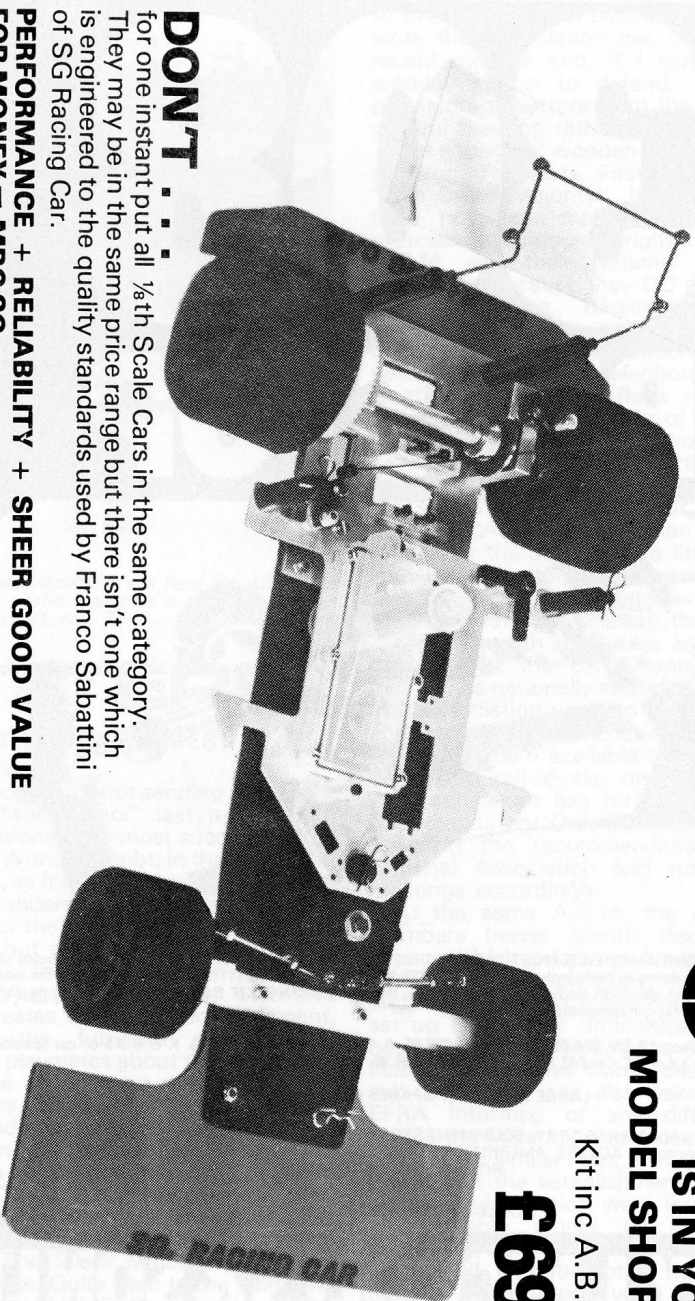
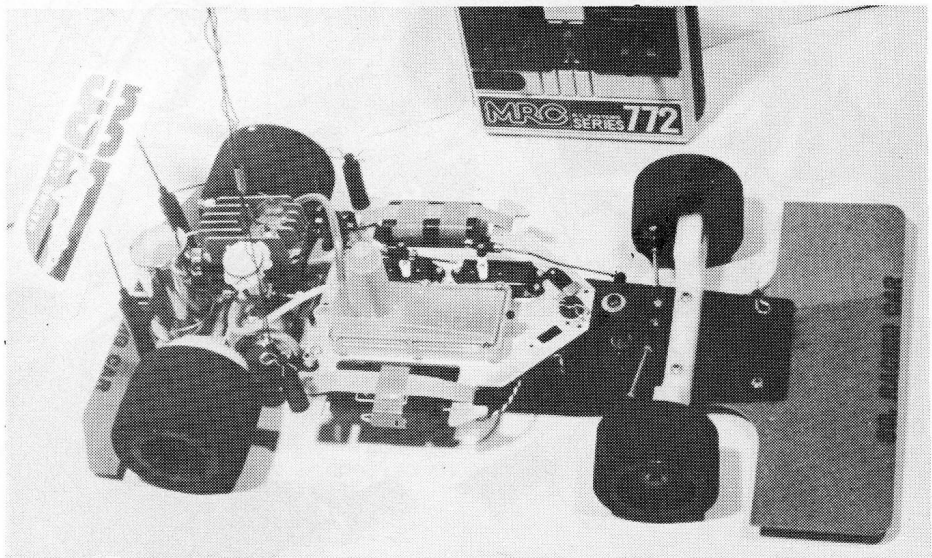

THE NEW

SG FUTURA 111

IS IN YOUR
MODEL SHOP NOW

Kit inc A.B.S. Body

£69.00
(inc VAT)

DON'T
for one instant put all 1/8th Scale Cars in the same category. They may be in the same price range but there isn't one which is engineered to the quality standards used by Franco Sabatini of SG Racing Car.

PERFORMANCE + RELIABILITY + SHEER GOOD VALUE FOR MONEY = MRC SG

From: **MODEL RECTIFIER (UK) Ltd**
Eastwood, Beverley Road WALKINGTON,
North Humberside HU17 8RP Tel. (0482) 882311



MRC



308 PIT STOP

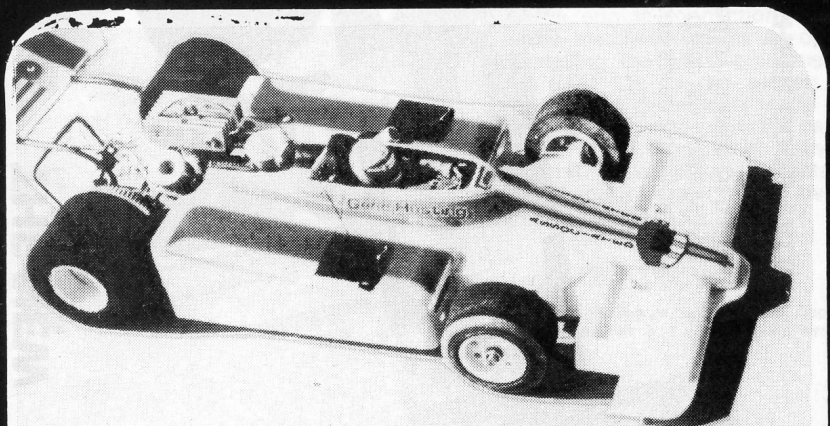

NEWS FLASH! AMERICA'S MOST SUCCESSFUL CAR KITS **ASSOCIATED RC 1** now with choice of Sports/GT or Formula body included in price of **£56.95**. **RC 100 COMPETITION KIT** ball bearings for rear axle and clutch also with body choice inc. **£79.95**. **RC 200 RACING KIT** Ball bearings for rear axle and clutch. All racing components **£119.95**.

ENGINES Veco 19 SM **£24.95**. Vec 21 SM **£28.95**. K & B 3.5 Standard **£39.95**. K & B 3.5 cc car special **£47.50**. OPS 3.5 cc RC Car **£42.75**. HB21 PDP Car **£34.95**. Irvine 20RC Car **£35.95**.

LARGE STOCKS OF SPARES FOR LEADING MAKES

ALL MAKES OF R/C EQUIPMENT STOCKED AND FULL RANGE OF SPARES
We accept ACCESS, AMERICAN EXPRESS, BARCLAYCARD, BANK AMERICARD,
HOBBYCARD, QUADBONDS

WORLD-WIDE MAIL ORDER

HENRY J. NICHOLLS & SON LTD.

The World's Greatest Model Shop for the Enthusiast!

308 HOLLOWAY ROAD, LONDON N7 6NP. Telephone: 01-607 4272.

(2 mins from Holloway Rd. Station on the Piccadilly line)

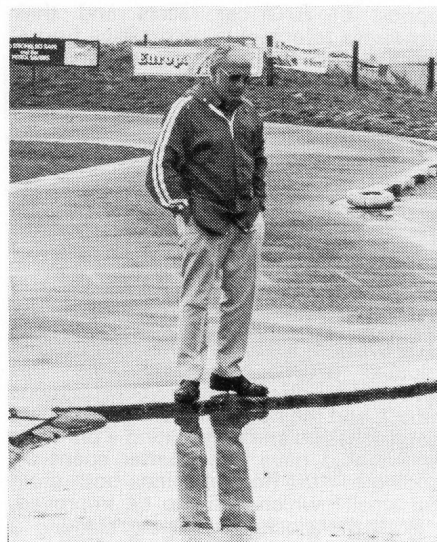

Secretary Disconsolate! It's a hard life when rain stops play... who would be a secretary... but you love it, don't you, Tom!

LETTERS..

"MOTHER KNOWS BEST" ...

Dear Dickie,

My apologies for not sending a birthday card to "Model Cars" last month with congratulations for a most successful first six issues. Without doubt, in that first year, each issue, as it appeared, was better than the last; readers began to respect your columns for the authority and reliability of your text; but then disaster. Issue 7! Can we ask? Was the wooden spoon a birthday present? What havoc an infant of twelve months creates with such an implement, smashing the furniture and fittings, beating its playmates about the face, while all the time crawling on the lush carpets provided by the sweat of its elders. Why, oh why, did someone not keep the spoon away from the babe until it grew old enough to do its homework?

Really Dickie, your ill-informed comments, with deliberate incitement to discontent, in your editorial under the heading "The Silent Majority", were an utter disgrace. Quite alien to the spirit and organisation which R/C car racers, EFRA and the BRCA particularly, have worked hard to establish since the early years. Your article headed "Electric R/C Racing — The need for a National Governing Body" is equally ill-informed with regard

to BRCA interest in twelfth scale and the work the Association has undertaken in recent months and, if I may use your wooden spoon to defend, times your premature departure from the last annual general meeting rather precisely.

But enough of wooden spoons and face slapping. The facts. Firstly your editorial "The Silent Majority". In the BRCA we have no silent majority. The majority exercises its democratic right to attend the A.G.M. and their National Reps hear everything because they DO speak up at the right time. Regional Committee members apt to say nothing are a breed unknown to the Association, well witnessed by personal telephone bills and lengthy meetings as Reps make every effort to improve "the host of things both great and small" to which you refer.

Your moan that "far too little has been done to get a proper twelfth scale electric car set-up going" and your accusation that "BRCA have so far taken little if any interest in the subject" are little short of libel. Unfortunately, unsuspecting readers may well believe your statements are true. How unkindly you misled them!

ROAR twelfth scale rules were adopted last year at the BRCA annual general meeting as nationally recommended rules. The Association went to no little trouble and expense to print copies of these rules and make them available to all clubs and interested individuals, but unfortunately the Association has no power to make rules mandatory. Only Clubs can do this by adopting the recommendations of the National Association and running their meetings accordingly.

At the same A.G.M. the Association members (never silent!) discussed the impact which adopting American based rules might have on clubs, manufacturers and importers and a sub-committee was set up to monitor difficulties and report back to the next A.G.M. to allow modification if this was found desirable. The sub-committee was also asked to keep EFRA informed of any difficulties to enable the Federation to proceed towards adoption of similar rules, BRCA being fully aware that the establishment of a set of national rules which were internationally unacceptable would be a worthless exercise. We would be failing the sport dismally if we attempted to implement national rules which were insufficiently researched and unacceptable internationally, or to any interest.

In the months following this action BRCA has advised numerous clubs and individuals on organising their twelfth

scale activity and interest. It is, indeed, gratifying to note that annual general meetings in 1978 will, in all probability, see both BRCA and EFRA endorse future use of these rules, with few modifications, in the sound knowledge that their organisation and rules for twelfth scale are internationally approved. Such approval represents a situation in twelfth scale which both BRCA and EFRA have yet to achieve for eighth scale, in spite of your suggestion that eighth scale is their only interest. If BRCA is guilty of anything, it is being too busy to blow its own trumpet. One can only wonder how so much was achieved, so quickly, by so few, with no direct interest!

May I suggest, Dickie, that in future you enter more fully into the spirit of R/C car racing circles and use gentle persuasion rather than the wooden spoon to encourage your readers to correct behaviour and democratic action. There are countless benefits in having one National Association for all R/C car interests; we have that Association already; The British Radio Car Association. An Association whose constitution, regularly up-dated to meet future needs, ensures that it will serve the best interests of the R/C car enthusiasts at all times.

However, while the BRCA exists to support R/C car racing it needs the

support of R/C car racers and their magazines to ensure a progressive future. May I suggest that you start an immediate campaign to encourage all your readers to join the BRCA, or at least to join a club whose officers are BRCA members, so that they are never again misinformed and can be seen to support the organisation which protects their best interests.

Finally, Dickie, lest you be tempted to prolong the debate and suggest that your article and editorial brought the BRCA out of hiding to talk, may I say that had you waited for our next A.G.M. before wielding the spoon, you would certainly have wished to write differently. Much valuable BRCA committee time was devoured by discussion of your infamous issue 7, and the hours of work in recording that discussion and formulating a printable reply would have been better spent attending to "the host of things both great and small" which need to be improved.

With the clock once again chiming 3 a.m. it only remains to change the date on the top of this letter, crawl to bed and utter the nightly prayer that constructive proposals will eventually replace destructive criticism, and tonight three extra words — "God Bless Dickie".

Yours sincerely,

TOM MARTIN.

Peterborough 17.9.78.

1/12 ELECTRIC CAR FOLK ATTENTION!

ATTENTION ALL 1/12 ELECTRIC CAR ENTHUSIASTS

There has been a growing feeling in recent months in the electric R/C car world that the rules, regulations and administration of this fast growing hobby should be decided at an open meeting specifically for electric enthusiasts.

A meeting has therefore been arranged for Sunday, 26th November, 2.15 p.m. at the Post House Hotel, Leicester.

This meeting has the support of all U.K. manufacturers and all clubs and individuals contacted to date and it is hoped that representatives from most clubs and individuals from all areas of the country will be able to attend.

Publicity for the meeting has been provided by R.C.M. & E. and Model Cars. The Post House is less than 2 miles from the M.1 (Exit 21).

For lunch reservations phone Leics. 896688.

**REMEMBER SUNDAY, 26th NOV.
— WE LOOK FORWARD
TO SEEING YOU**

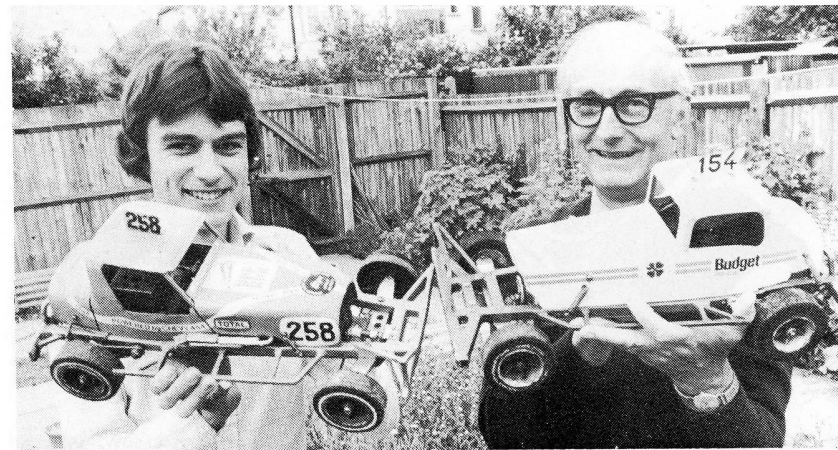
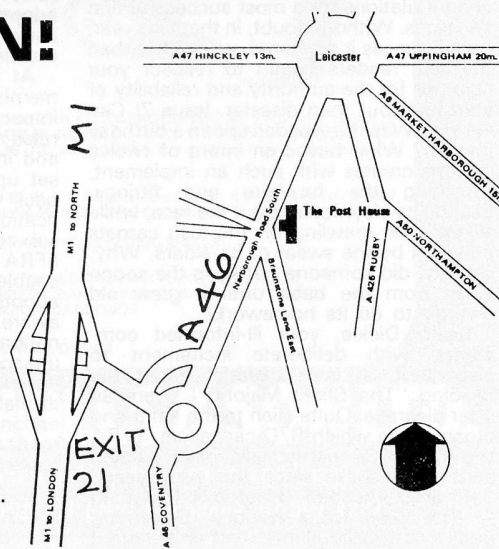

STOX ON MAGPIE...

On the 14 January, 1978 we were invited to Wimbledon Stadium by Spedeworth International to put a show on the full size track during the interval of their programme.

Following this show on Saturday night, the phone rang at my office on Monday morning from someone connected in Television (who was in the Stands) to say why don't you try and get on Television! Without more ado, I called at Thames Television reception in Teddington, loaded with photographs and Model Stockcar, "saying I had an appointment with Tim Jones the producer of Magpie. He was sent for, and I was greeted by him, "You have no appointment with me, you've got a B... cheek, but I admire you! What's that in your hand? After investigating my wares, he remarked, what a B... good idea". He introduced me to Jill Southcote the researcher, for her to follow up and organise a trial Race meeting at Chessington circuit, the Film director would be present, to see the suitability of presenting a programme of this nature. Of course he was sold on the idea, and gave orders as to what he wanted, which included a car to carry and run a camera behind the cars on the circuit. This I undertook, and using my own Stockcar chassis, strengthened it to take the weight of the smallest camera available, some 8lbs., making a strong platform with a 3/8" hole for fixing. I checked my Veco 19 engine to see if it would pull the weight which it did, and waited for the day of filming.

JACK BYE TELLS THE STORY

The phone rang, and we only had a few days notice, to say Tuesday, 11 April at Chessington 10am sharp. Plans were put into action and I arrived at the site 10am to find the camera already rolling, the track half down with people dashing about in all directions, and the rain coming down! I approached the Director with a view of calling it off, and he remarked: "No way! This is more authentic, look at the water coming off those tyres," After filming the static part-built models, came the Stockcar racing in general. Then the full size Formula 1 Stockcar arrived 258 and 55 (still raining) cameras rolled again till lunch break. After lunch everyone was wet outside and many wet inside with 70% fuel (whisky). So by this time we all ignored the rain, now came the crunch, let's have the Stockcar with the camera!

Opening of metal boxes, "this camera hasn't been used for 2 years", and the weight 14lbs. I fixed it, and had my doubts the engine would not pull it, but it did, on full throttle; it went round about walking pace with my son Roger at the controls. The Director called out, "It's all right we can speed up the film." After a few laps, he again called: "Turn it over, Roger, crash it," but it wouldn't, it was too heavy.

So the answer to your photograph on page 3 of No. 7 issue is: Jack Bye produced the Car and Roger Bye was at the controls.

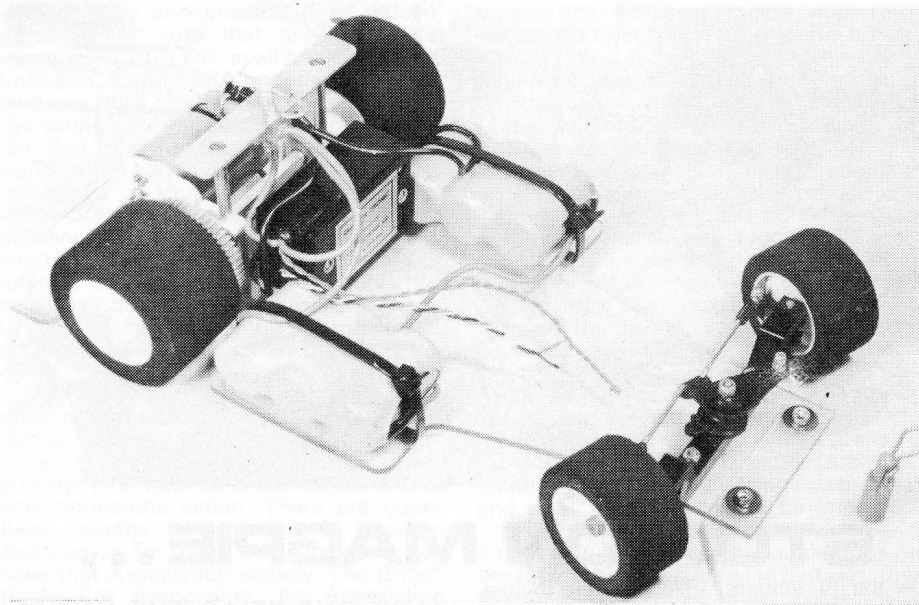

SPECTRON

NEW BRITISH 1/12th ELECTRIC

ONE of the very first people I got to know when the Ally Pally Electric Car Club was in its infancy was Richard Gammon, then intent on perfecting his Smoothtronic speed controller fitted, I believe originally to the then only car — Lectricar available, but soon to be transferred to his first scratch-built. He was always knowledgeable about plastics as well as electronics, and soon was obviously working towards a production kit of his own. Well, he has taken the plunge and is now whole time engaged in model manufacture, with the first fruit of his efforts coming fast off the assembly line in the shape of the "Spectron."

This is a kit for the connoisseur. It will cost you £76.68 including VAT. What will you get for the money? Here is a brief specification: Polycarbonate chassis 3mm thick, duly waisted, with rear bumper, indented for battery cable ties, plus separate polypropylene front bumper of adequate size to enable a whole range of bodyshells to be used. Welded battery packs with heavy duty leads in heat shrunk dustproof sleeving secured by cable ties and servo tape. Standard RS54 Mabuchi motor, 54/14 gear mix — but slotted rear axle hanger to enable other combinations

to be used. Rear wheels trued and glued to ensure no errors in rear balance. Popular hexagon section for non slip fitting, and compatibility with most U.S. accessories. Axle machined to close tolerance to reduce gear chatter and avoid bearing slackness. Coming to the front we have heavy duty front axle assembly, with circlipped kingpins. Glassfilled nylon servo saver, all linkage adjustable via ball and socket connectors. You will have to glue on your own tyres at the front in the usual way.

What more is there? We almost forgot, you get the latest Smoothtronic speed controller included for your money, now with regulator integrated in the circuit and the usual dynamic braking facility. And still more, a polycarbonate bodyshell is provided pre-painted in two colours with choice of Porsche, Lola, Abarth Alfa. These are nearly ready to fit, requiring only trimming to bodyline.

This leaves you with only radio to install and one servo to provide plus aerial rig.

Just a bald statement of kit contents but we should also mention some of the subtle refinements. Rear body posts are joined with a stiff cross piece which incorporates the rear body fixing peg in the centre, and

Left: This is the kit as made up — plenty of room for Rx and servo (only one needed of course)

Right: Rear view of kit assembled. Note rear body posts and cross fixing strip, with charging sockets fixed below.

This is the Spectron run for quite some time now by Wendy Bork. Just for a change Skyleader Rx and servo are fitted and have given complete satisfaction — but plenty of room.

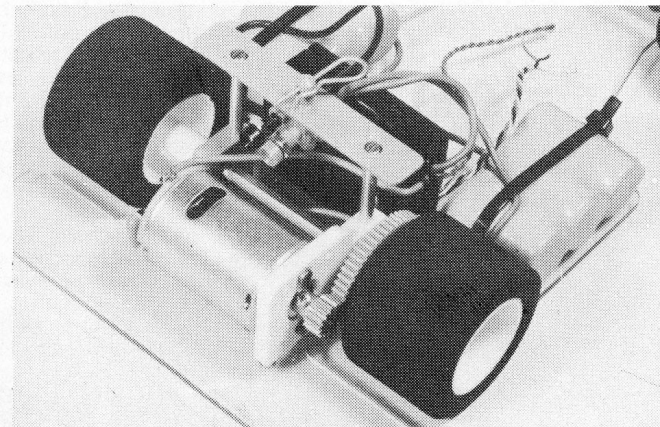

has the two charging jacks just below. This fixing strip imparts complete rigidity to the rear end, while leaving the chassis to flex as required. You should see it run over rough board, like a "jelly on springs" . . . On/Off switch for radio can also be conveniently fixed on this cross support. Then the front bumper is rivetted to the chassis. This gives very strong attachment and also enables the smooth bottom of the rivets to slide easily over any uneven surface. On frontal impact it can bend right up and over protecting the front of the car from damage, and even reducing effects of impact on the **other** car! With thoughts of rough surfaces and screw-loosening activities self-locking

nuts are used on front suspension and linkages which prevent a lot of grief. (Some very neat little box-spanners for these small sizes can be obtained from Charles Kennion of Railway Place, Hertford, or Charles will be at the M.E. Exhibition of course).

Even the box the kit comes in is designed for after-use. It takes the car as built up for transport to the club, always a problem unless one sets to and makes up a purpose built carrying case.

Initially Richard's own company I & D Electronic will be handling mail order from Barnes. This is good winners' kit and a lot can be expected on the circuits by the new year.

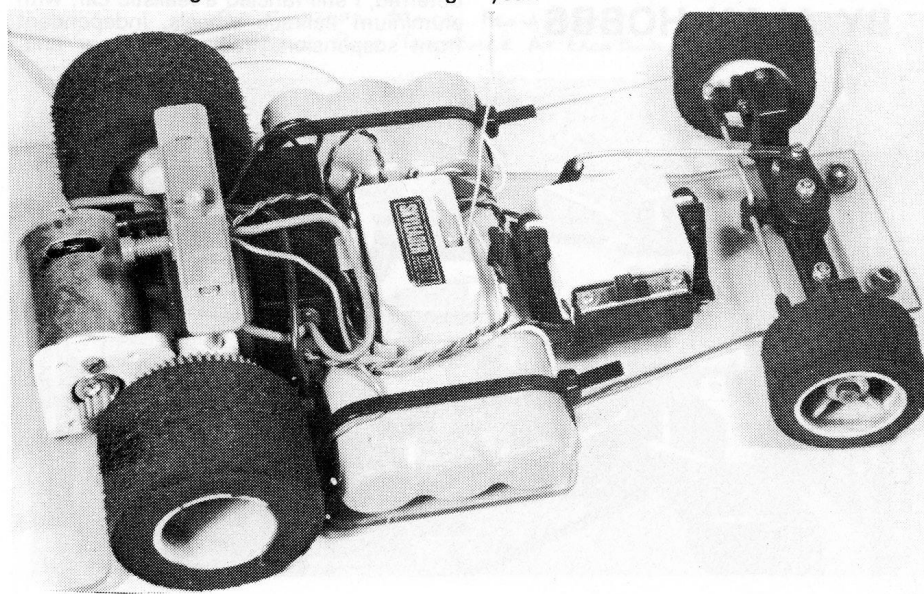

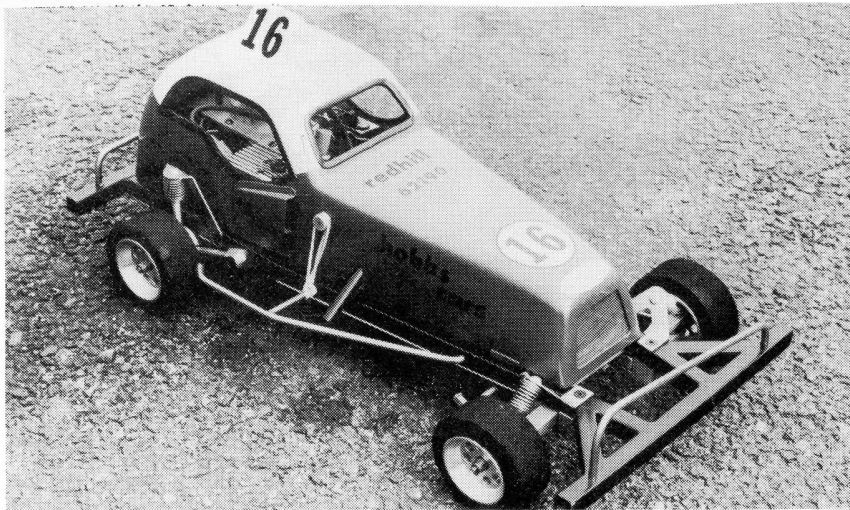

"HOBBS SPECIAL" STOCKCAR

BY ALAN HOBBS

IT was about two years ago that I first saw a Radio Control Model car being driven around a local car park. I was immediately impressed by its control, speed, and response, but disappointed by the quality and design of the model. Therefore, after the result of much comment, I was soon told of the £35 limit (the car without radio and engine must cost less than £35) and challenged to do better for the price. It was then I realised what good value these cars are for the money. But not to be deterred, I still fancied a realistic car, with aluminium ballrace wheels, independent front suspension, trailing arm rear end,

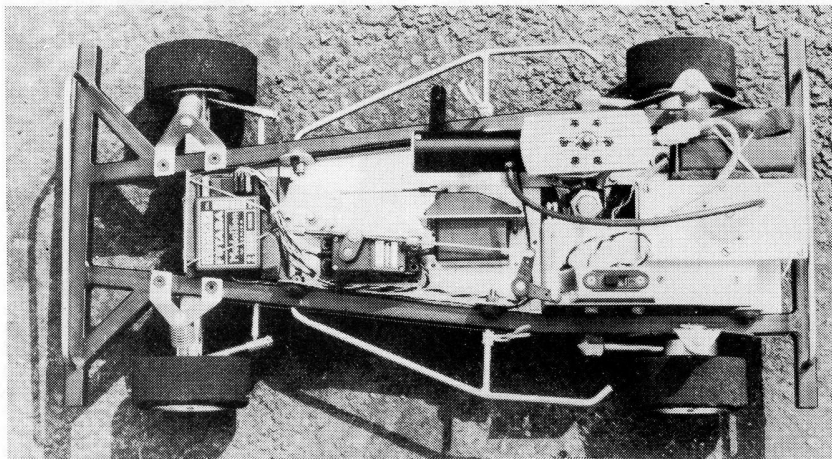

etc., that really worked. This I was convinced I could do (within the cost limit) provided I made all or almost all the parts. This presented the first big problem—I have no machines. After a few enquiries, I signed on at a metal working course at the local technical college, which meant I now had access to a full range of machines two hours per week with instruction (in fact, I only used 3 machines).

Now the designing could start, but first a trip to a Worcester Park Model Shop to purchase a body (available in plastic or fibreglass), set of tyres, a drive belt and a clutch spring. This allowed me to draw up the chassis to suit the body shape, likewise the wheels to suit the tyres and so on with the clutch and drive gear.

The chassis is designed flat to line up with the body shape and is presented to a welder clamped to the required dimensions. The width at rear being important to obtain the correct engine position, as too far one way and the cylinder head will burn a hole in the body (this I learnt the hard way), the other way and the clutch will rub the chassis. I finished the chassis with coats of zinc and matt black aerosol paints.

The body is positioned on the chassis with six half round rubber buttons, these absorb the vibration and make for easy location of the body, which is retained to the chassis with two rubber bands on to two grease nipples fixed in the body. The

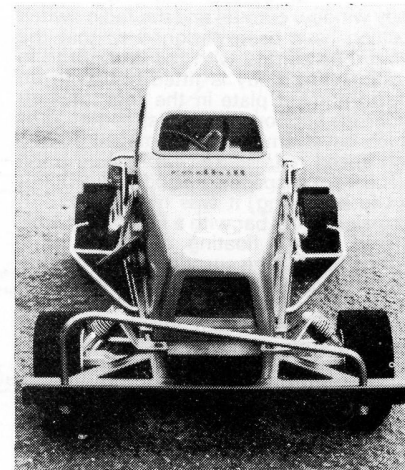

Elegant "Hobbs Special" ready for battle.

Left: Arrangement of components: note springing.

Above: Robust front view of the car.

Below: Sketch showing clamps required for welding.

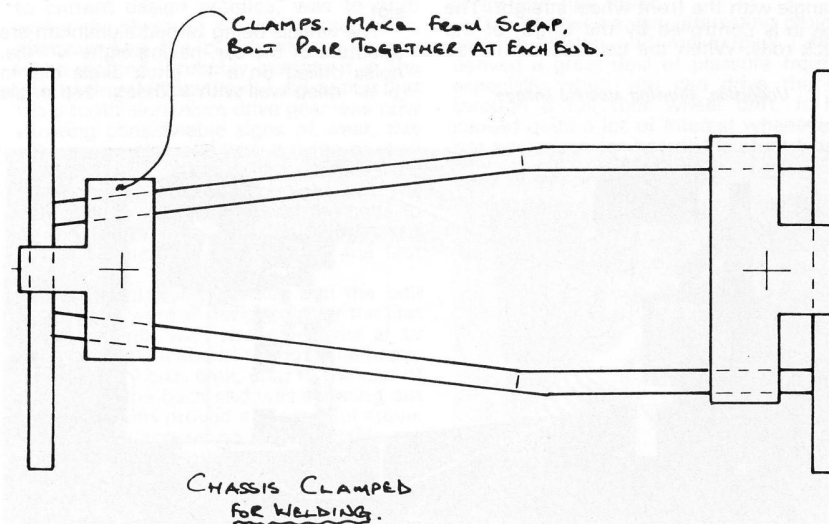

body window cutouts and the radio switch position have been designed so that the car can be started with the body fixed in position. The body is fitted also with an angled number plate in the roof, plus an underside support plate for strength, all of which have remained undamaged after a high speed roll.

The front suspension being independent had to be strong, it was made from $\frac{1}{2}$ " thick aluminium bar with a fork swing arm, located with a floating dowel pin in a bearing block. The suspension spring rate can be adjusted by fitting a further spring inside the located spring. In order to have true independent front suspension with swinging arms the track rods must function through ball joints. After searching the market unsuccessfully for a simple ball joint, I designed my own, which is basically a ball rotating against a spring in drill point angled hole. It requires the manufacture of a small form cutting tool, made by drilling a $\frac{3}{16}$ " dia. hole in a piece of soft gauge plate or silver steel, filing to shape then hardening and tempering.

The steering involved trips to the library in order to study Ackerman Angles, toe in, caster and camber angles. I need now look no further than issue two of the magazine (pages 19 to 21) for a full and complete story. The correct Ackerman Angle was achieved with the aid of a full size drawing and was therefore, designed in the car from the outset. Basically the king pins, 2 steering ball joints and the rear axle form a triangle with the front wheel straight. The Toe in is controlled by the length of the track rods. When the car first ran it had

Underside, showing steering linkage.

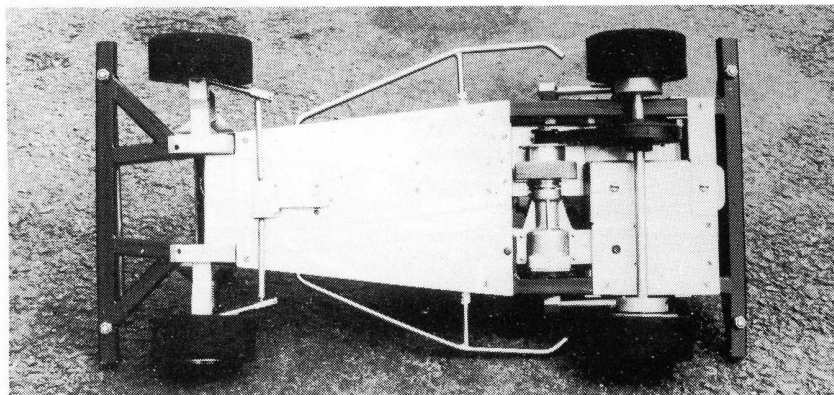

adjustable track, this proved unnecessary and unreliable as once you got the car set, adjustment is not required. This was found after breaking a track rod at the point of adjustment. Basically aim for $\frac{1}{16}$ " toe in on each wheel at its rim. On the caster angle I have plumped for no angle, but placed the king pin behind the axle centre, purely for ease of manufacture. It achieves the correct effect and allows one to make right angled swinging arms, bearing blocks and stub axles, etc. The camber is set by the position and angle of the top spring location plate attached to the chassis and can only be checked when the car is complete due to its weight on the springs.

The centre steering boss and servo saver unit was first mounted in an old Hoover washing machine ball race, this looked a bit bulky and after further development was changed to a plain bearing design as it was found to work equally as well. The steering servo was originally mounted in a standard Futaba servo mount, this was found to be a bit too flexible and was subsequently changed to an aluminium right angle bracket for more positive steering.

The rear suspension utilises the same coil spring as the front end (likewise the servo saver spring) which can be equally adjusted by adding a spring inside, as at the front. The difficulty with the rear end was to get the bearing blocks or trailing arms to swing as on a ball type joint. This was achieved by locating the trailing arm in the bearing block with a pin rotating in a slot.

The wheels being turned aluminium are a feature of the car, having eight $\frac{1}{4}$ " dia. holes drilled on a 1" pitch circle dia. in a $\frac{3}{8}$ " deep well with a 25deg. lead angle.

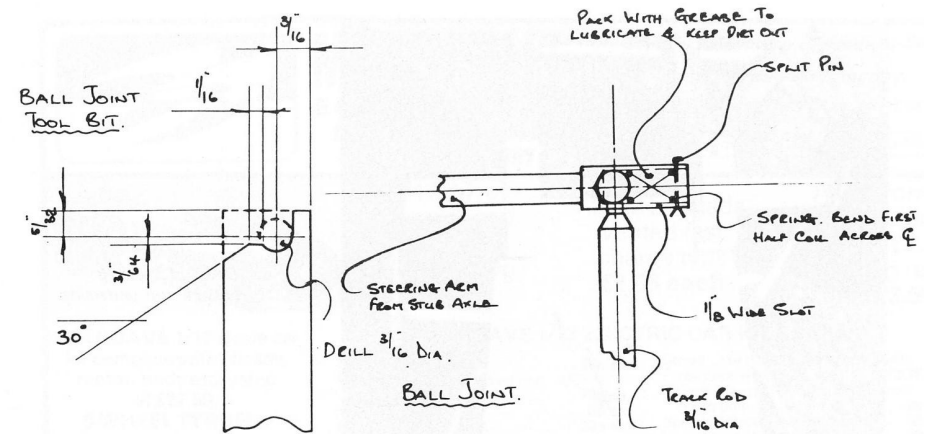

Ball joint and form tool required for making it.

These wheels being turned aluminium run very true and are easy to clean with solvents (removing old tyre glue), but the front wheels had to have two ball races fitted in each, due to the radial play in each ball race. The rear wheels are keyed to the axle which run in two bearing blocks.

The clutch I expected trouble with, this was not to be, as after bench testing it, to check that it did and did not engage, it has run very successfully. The only modification I did which does not conform to current design practice, was to grub screw the flywheel to the centre arbor, after winding the clutch off the engine when starting (probably starting it in the wrong direction anyway). I did notice that the 8 tooth aluminium drive gear was now showing considerable signs of wear, this will now be replaced with a nylon or steel gear. Note, do not run the car with the tension of the tooth belt too tight, as it will only stall the engine. I found the belts to be very tough (nylon inserted) I purchased 3 initially, but I am still only on the first one.

The two underpan plates and the belt guard plate were all designed after the first years running, with two objectives a) to keep the dirt out and b) to move the heavy gear (battery box, tank, etc.) to the rear of the car, as the back end was spinning out too easily, this proved a successful move. Note all the screws on the underside are counter sunk, as rubber starter wheels do not like catching sharp little objects. The receiver and battery are both mounted in foam secured with rubber bands.

After toying with a few ideas I finished up using a standard PB tank for the fuel which I considered a bargain at £2.

The engine throttle servo set up was originally arranged across the car, this proved difficult to set up when removing and refitting the engine. It has now been changed to operate at right angles through a bellcrank for ease of adjustment. During the first year's running a lot of difficulty was experienced with engine stalling and starting. This was due to dirt so it's a must, fit air and fuel filters.

This has been a very interesting project, both to design and make, plus I have derived a great deal of pleasure from it, especially when you can drive the car through a full four wheel drift. It has caused quite a lot of interest whenever it has been seen (or heard) therefore I have

Detail of springing.

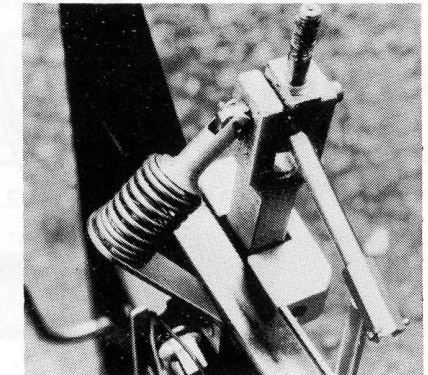

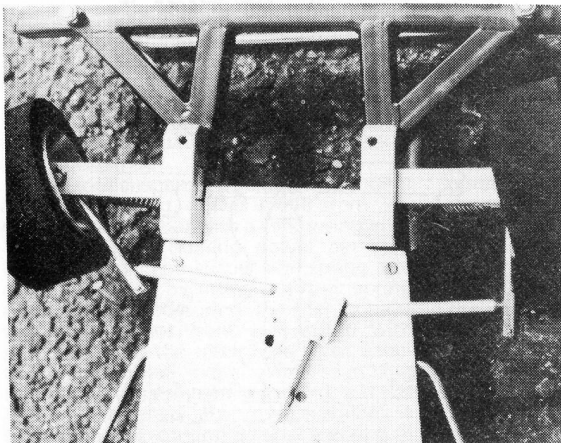

Detail of steering linkage and underside.

decided to make available a full set of scale drawings. Now, this is a lot of drawing over 25 square foot, fully detailing 65 components for the metal working model maker, so it won't be cheap. I made it using mainly a small lathe and drilling machine, with a small amount of milling, plus a bit of chassis welding (which I paid a man £1 for). But there has always been a restriction to the project which I have been careful to observe, namely the £35 cost limit. It is now beginning to show as there are only two major manufacturers of stock

cars in the country and the market is stagnant. No new kits or parts, but move over to Formula 1 and you have a different scene. O.K. the kits are double the cost, but the market is really on the move. New goodies, diffs, tanks, etc., coming out each month. There must be a moral in this somewhere. The result of which I have now gone over to Formula 1 and have had a car running this year with a special chassis frame and hydraulic disc brakes, yes hydraulic. So you may hear more from me.

Radio, fuel tank, on-off switch and engine in close-up.

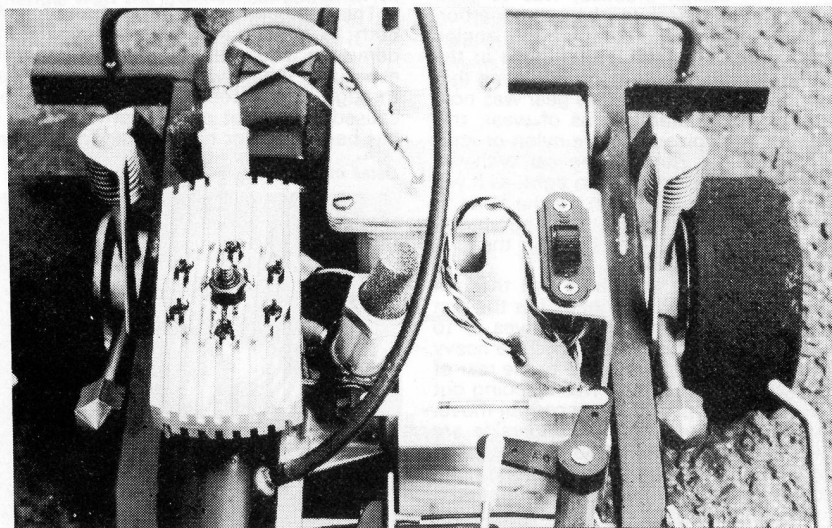

MODEL CRAFT
5 CROSS ST. BLABY
LEICS. ENGLAND
TEL. 0533 771397

SHOP OPEN 9-6 p.m. Mon to Sat.

Closed all day Wednesday.

RING IN YOUR BARCLAYCARD OR ACCESS

POSTAGE: Parts 50p; Decals 10p, Kits FREE



1/12 driver figures solid cast, very detailed 49p each

1.2 A.H. Nicads, vented fast charge type £1.65 each

Alloy front wheels for Mardave £3.60 Matching rear Trims £3.60

MARDAVE 1/12 Scale car kit complete with Nicads, motor, body etc. value at £37.50.

6 WHEEL TYRRELL

ABS bodyshell plus instructions on how to adapt to the standard MARDAVE electric car chassis Price **£3.95 P & P 35p.**

1/12 scale bodies ABS

F1 BRM	£1.45
F1 Ligiers	£1.45
Porsche Saloon	£1.95
BMW Saloon	£1.95
Shadow G.T.	£1.95
VW Beetle	£2.50

MARDAVE SPARES 1/4 SCALE

Rear axle bracket	70p
Brake unit	33p

SERVO SAVER

Steering bellcrank complete	66p
-----------------------------	-----

FRONT SUSPENSION

Complete	£2.90
King Pins	10p ea.
Coil springs	10p ea.
Axle, with nylon block	20p ea.
Steering arms, LH or RH	20p ea.

FLYWHEEL/CLUTCH UNIT

Complete	£3.75
Clutch shoe	25p ea.
Tubular pins	3p ea.
13t hardened steel gear	70p ea.
Bush for gear	25p ea.
Cork lining	6p ea.
Clutch drum complete with gear and cork lining	£1.60
Clutch springs	8p ea.
REAR AXLE	55p ea.
Bearing	20p ea.
Bearing lock nut	9p ea.
1/4" Nyloc nut	6p ea.

WHEELS	
Front	35p ea.
Rear (with integral drive gear)	70p ea.

MARDAVE 1/12 ELECTRIC CAR KIT SPARES

Chassis plate, drilled	95p ea.
Front axle beam moulding with steering arms	70p ea.
King pin	6p ea.
Bellcrank	20p ea.
Bellcrank attachment nut	6p ea.
Front stub axle with nut	12p ea.
Track rod, complete with over-ride stud, springs and collars	70p ea.
Rear axle bearing blocks (Pack of 2 with 4 screws)	70p ea.
Side trays (Pack of 2)	70p ea.
Front wheel	25p ea.
Rear wheel with 2 grub screws	55p ea.
Front tyre	35p ea.
Rear tyre	70p ea.
Rear axle	15p ea.
Drive gear (Hardened steel gear with 2 grub screws)	75p ea.

Speed controller (Complete with resistors, wiper arm, etc.)	£2.75 ea.
Speed controller printed circuit board only	90p ea.
Speed controller resistor only	30p ea.
Speed controller nylon wiper arm	20p ea.
Speed controller pivot stud, for wiper arm	8p ea.
Speed controller brass contact	8p ea.
Speed controller coil spring	8p ea.
Aerial/switch plate, black nylon	30p ea.
Throttle servo/speed controller mounting plate, black nylon	30p ea.
Front bumper plate	35p ea.
Charging leads	£2.95 ea.
Collars, for linkage wires, with grub screw	15p ea.
Screws, any size	3p ea.
Nuts any size, except nyloc	1p ea.

TYRES

Front, standard rubber	60p ea.
Front, hard rubber	70p ea.
Rear, standard rubber	£1.05 ea.

RADIO CRATE

Driver figure	£1.30 ea.
---------------	-----------

FUEL TANK

Driver figure	26p ea.
---------------	---------

ACCESSORIES

Engine silencer	£2.35
Engine heat sink (for extra cooling)	£1.25
Transfers (Giant size sheet, 84 sponsors decals + 35 numbers)	£1.25
Starter sheet (4" dia. hard rubber, for electric starter)	£1.35
Air filter for Perry Carb	80p

STOCK CAR

Silencer	£2.35
FRONT SUSPENSION Complete	£2.50

REAR SUSPENSION

Radius arm	38p ea.
Radius arm spring	15p ea.
Radius arm attachment nut	12p ea.
Rear axle	40p ea.
40 Tooth drive pulley with tube pin	70p ea.
Drive belt	55p ea.
FLYWHEEL/CLUTCH UNIT Complete	£3.75
Clutch drum with 8t pulley, cork linking and retaining washer	80p

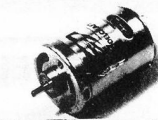

'Cyclone' type motors Mabuchi Re. 54. Only £2.99 each

Hollow 'Boots' for outdoor running. Fit over standard tyres either treaded or slicks 91p per pair front or rear

Irvine 20 car now in stock Schneurle ported, dyke ring, metal carb, very potent at £35.94 all spares available

Alloy front axle beam to fit standard Mardave parts. 8 deg. camber incorporated transforms the handling

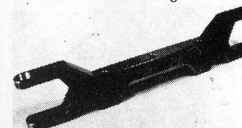

BRITISH NATIONAL 1/12 ELECTRIC R/C CAR CHAMPIONSHIP

Modelcraft's Team Rojar won Team Prize; Team Members Tony Whitehorn 1st, Les Pipe 2nd. Concours: 1st Colin Spinner (Shadow GT) (Modelcraft customer); 2nd Tony Whitehorn (Datsun 260Z) Cars "out of the box" Mardaves plus 6-speed forward and reverse Michrome Resistor (£4 from Modelcraft). A triumph for the "standard low price car!"

NEW ASSOCIATED RC 200 KIT

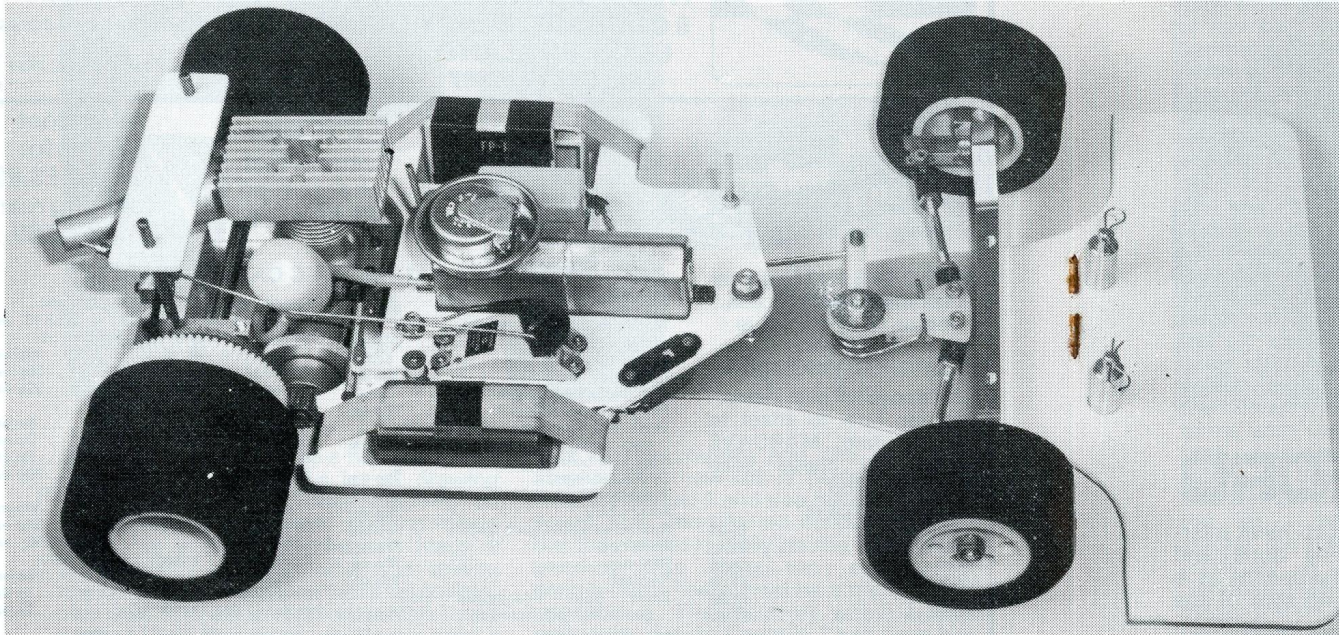

NEW FEATURES

Aluminium Front End
 New Servo Saver
 Ball Joint Tie Rod
 Fibreglass Chassis
 Disc Brake
 8mm Rear Axle
 New Rear Pod Plate
 New Gear Material
 Plus Fuel Tank

PROTOTYPE RC200 CARS WERE USED BY WORLD CHAMPION, BUTCH KROELLS, AS WELL AS THE FIRST 7 PLACE FINISHERS AT THE WORLD CHAMPIONSHIPS.

1977 EUROPEAN CHAMPIONSHIPS



PER GUSTAFSSON—SWEDEN
 SPORTS CHAMPION



UDO FRANKE SWITZERLAND
 FORMULA CHAMPION

1977 USA ROAR NATIONALS



ROGER CURTIS
 SPORTS CHAMPION



BILL JIANAS
 G.T. CHAMPION

1978 BRITISH G.P.



DEBBIE PRESTON

1st BRITISH G.P. Sp/GT
 2nd WORLD CUP MONACO
 3rd EURO. CHAMPS Sp/GT

ASSOCIATED 1928 East Edinger, Santa Ana, CA. 92705, USA



EURO-CHAMPS AT LILFORD

THE "once in ten years" occasion of hosting the European Championships in Britain presented a challenge to the BRCA and the Lilford Park Club that all were quick to take up. Tom Martin, BRCA secretary and prime mover at Lilford took all the necessary steps to enthuse his numerous band of helpers with first task



the extension of the circuit to meet international requirements. This done and offered earlier to visiting Europeans as a taster was really the opening shot of the campaign.

Lap times looked fairly even across the board with 20 secs a lap, making a 15-lap five minute heat seem about the qualifying level. Formula programme for Saturday's racing was arranged to take the slower cars in the earlier heats, working down to the aces for heats eleven onwards. The Italians who had arrived later than most did not practice very hard and were generally allotted fairly low number heats.

This then was the pattern for Saturday. Racing started immediately after breakfast, and from heat five onwards times were getting better and better with thirteen laps to the 5-minute heat coming up fairly freely, plus a couple of fourteens and one solitary 15 lap turned in by Franco Sabattini. Then at about heat ten of the first round disaster struck! The rain which had been threatening with occasional spitting came down in buckets and brought racing to an abrupt end. Under the rules the maximum break in a day's racing must not exceed one hour, during

Drivers stand behind their mechanics for start of Sports/GT Final. Left to right: Peter Bervoets (2nd), Debbie Preston (3rd) — Dad is mechanicking — Ronnie Ton (4th), Dave Martin (1st) with slick Ted Booker mechanicking, Peter De Carro (5th), Phil Greeno (6th).

Left: Sabattini in the wet on Saturday — faithful team mate shelters him.

Thirans of Belgium, surprise winner of Formula on Saturday, poses his car in the sunshine of Sunday.

which time organisers and team managers must agree on procedure for continuation, or abandon the meeting, or postpone to another day. Some years ago in Italy (of all places) a similar situation arose and it was then agreed that the show must always go on whatever the weather. Consequently, when a vote was taken, all but two votes, were in favour of a straight continuation after the one hour pause. A suggestion that heats already run should be cancelled and new start made was not adopted.

Rain had nearly stopped by 12.30 when resumption was required. Brooms were sweeping the circuit, and an escape hole for the surplus water had been driven into the off circuit concrete. Swirling round with spumes of water spurting from wheels, the aces of the r/c world were set the almost impossible task of getting on terms with the early runners. No one in fact achieved even another 14-lapper . . . best being Vincent of France, Bob Denton GB, Bernascone, I and Errington GB . . . with the big names down among the high twenties to forties. This produced a straight-in top four of Sabattini, Italy Olsson, Sweden, Thirans, Belgium and Collina, Italy. The two Italians had indeed been Euro-champions in their day — the other two were amongst the up-and-coming youngsters. The sub-final had Ruchat, Switzerland, Strupler also Swiss, Kruhsberg of Sweden, Van Helden, Holland and two newcomers from Austria Maringer and Andexlinger. Ruchat and Andexlinger proved the winners and moved into the final.

The race was run at a very moderate tempo with Collina and Andexlinger trailing

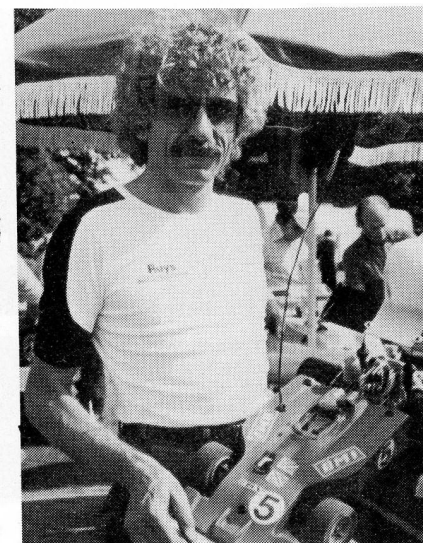

behind the tightly bunched leading four who stayed on the same lap virtually throughout the race with lap times only in the 26 second range! Thirans and Sabattini enjoyed the advantage for the most part of being out of the spray cast up on following cars, but this was a very minor gain with Ruchat and Olsson so close on their heels. Significantly all were running with differentials of one or other of the makes now available. As the finish

Keith Plested's own PB Int. full of his latest devices, new air filter, diff., slide carb., servo "wet covers" . . . PB winners were virtually both straight out of the box!

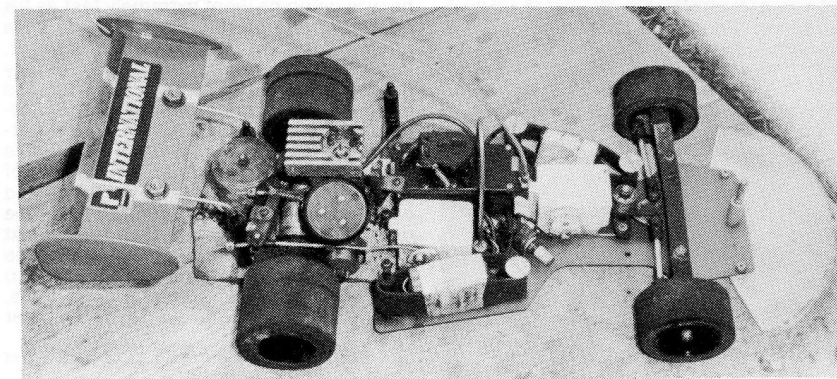

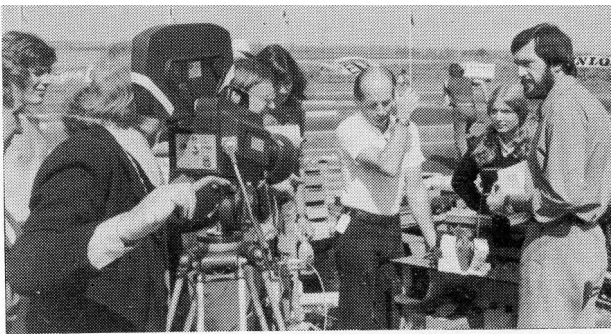

TV camera crew spent a busy morning on pre-race Friday for a December issue of *Modellers' World*.

The winners: Peter Bervoets (2nd), Dave Martin (1st) and Debbie Preston (3rd) with Ted Longshaw at the mike.

hooter sounded Thirans was in the lead with Sabattini closing fast on Ruchat with only feet between them, Olsson a lap behind. With Thirans over the line crowds surged onto the track and Sabattini slowed up instead of pressing on to the line when he would very probably have overtaken Ruchat.

A heated enquiry followed, with Sabattini claiming he was unaware of the rule requiring the last lap to be completed, and claiming that in any event he was impeded by the crowd and could not have run on at full speed. Race result as given stood, and Sabo was a very unhappy man. He declared he was going straight home without further participation; this he did not do but refrained from running in the Sunday event. With bad weather as the villain of the piece, the one virtue that came of it was that comparative newcomers to racing, the Austrians managed to get two places in the top ten to their great joy and encouragement, and that Thirans, a very competent and hard-working driver was given a first share of the limelight.

With the usual inconsistent English weather Sunday dawned bright and lovely and times immediately reflected the better conditions. Fourteen laps became almost the norm (35 out of 87 achieved this or better); the leading eighty drivers all got 12

or more laps in. Leaders with 15 laps were Ronny Ton, Phil Greeno, Peter Bervoets and Peter De Carro — distinguished as the only one of the top ten in each day's racing NOT to be running with a differential. As a Delta driver it rather points the truth of the Delta claim that their road holding is superior.

Sub Final saw a strong British contingent in pursuit of a final place in the shape of Dave Martin, Debbie Preston, Steve White, Ken Wright and Bob Errington, with Mares of Italy the solitary European visitor to make it. Dave Martin and Debbie Preston proved the popular winners.

Final had a nice range of cars involved with two PB Internationals, a Dutch Serpent, Italian Futura, and two from USA Debbie's RC200, now with AMPS differential and Peter De Carro's Delta — the latest Super J, first seen in Art Carbonnel's hands at Monaco. Once again the final soon split into two groups Dave Martin leading from the hotly contesting Debbie Preston and Peter Bervoets. Phil Greeno never really showed as radio failure, principally servo trouble at the steering end left him a trailing sixth. When he was going he went extremely fast as his qualifying 15-laps showed and could have provided strong competition. However, Dave Martin, running what was a very nearly standard PB International, with the latest glassfibre chassis and PB differential, put up such a remarkable performance that only a superman could have bettered it. His 93 laps in an official time of 30:13.7 if we take out refuelling time and one flame out gives an average lap time over the half hour better than the fastest qualifying time! That Peter and Debbie were within one and two laps of him is also a great credit to their driving skills. Alas, Peter seems fated always to be Number

Jeff Lindstrom demonstrates his superefficient Thorn monitoring equipment.



Two on these occasions — it must be his fourth 2nd place! Debbie, too, did excellently with impeccable driving, and a furious dice with Bervoets, with places changing lap by lap, to the joy of a large and enthusiastic crowd. Ronnie Ton and Peter De Carro were by no means disgraced in a really racing pace event.

As a graceful tribute to a great occasion Lord and Lady Lilford, whose estate Lilford Park is, hurried back from holidays to enjoy the final and present the prizes. BBC television cameramen were also present to take material for use over the Christmas period in a new *Modellers' World* programme.

What are the salient points of the meeting? First and foremost that the introduction of differentials is having a vital influence on r/c car racing. The fact that John Thorp's (and the Brem version) differential made little or no impact over the years that it has been in existence can be put down to the fact that it was associated with a belt drive, and thus its particular value was until recently not appreciated. We now have three major differentials in new production: AMPS which is the most developed so far, and is already being adapted for use with Serpent, SG, and Associated cars in addition to original PB International version. Then we have PB's own variant which uses spur gears instead of bevel with some slight theoretical advantages. These two diffs.

Very useful starterbox cum worktable, cum wheel and tool storage now on offer from H. Fett, Lovenicher Weg 15, 5,000 Cologne.

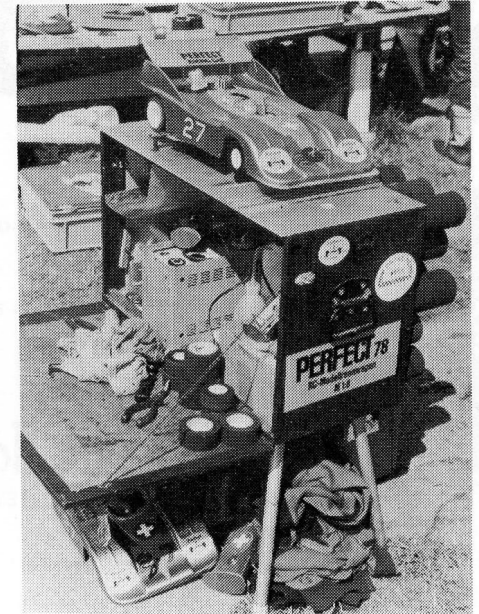

certainly showed some signs of its short development time (the nine weeks since Monaco) with reports of axle bending. When it worked it worked well; only need is to find the ideal metal combination, and this is simply a matter of time.

The SG Futura also showed up well in competition with six places in the first twenty places (two runs of ten). Also with new kits on trial were Sweden's Minicars' Challenger in latest form and FWF's Serpent. Two Deltas in hands of De Caro and Strupler (Swiss) were seen, and Debbie Preston's Associated RC200. Finally, there comes the seven PB Internationals to make up the twenty; this needs no further comment other than to repeat that first place in each event went to a PB car in more or less standard trim. This is as opposed to the winning Monaco PB which in Phil Greeno's hands had received a great deal of attention.

All the Italian cars and the SG supported entries were running on the latest Super Tigre X21 RE, numbering four in the top twenty, plus three other earlier STX21 engines. K & B claimed another seven leaving the last six for OPS. In other directions, improved disc brake systems with better adjustments were seen; better air filtering with very fine screen dirt kept out; and more attention paid to protection from wet and other hazards of radio equipment.

Mention must also be made of the splendid radio equipment monitoring provided by Jeff Lindstrom with equipment on loan from Thorn's. This enabled a positive check to be made at all times and on all frequencies. With a wide European spread there were in fact many unknown wavelengths involved but Jeff could catch them all. The illuminated screen produced hillocks for each band when receiver on, extending this to a line when Tx also on. Any maverick would also show up. Screen could be switched in a moment to any other frequency band for checking. There

The Dutch Serpent, latest version soon to be available here. This is Peter Bervoets' car.

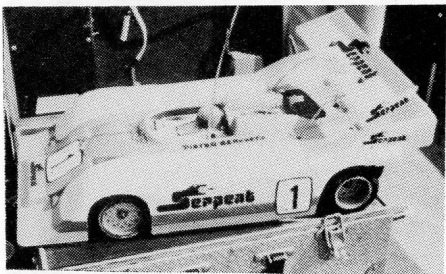

was not a single racing failure due to radio interference. In case clubs might fancy similar equipment I am told it costs around £8,000 plus and demands a skilled operator (and rich).

The social side of a meeting of this nature was also in evidence with a Championship Banquet in nearby Peterborough. Tom Martin told me rather whimsically that many more attended than tickets had been sold but added that perhaps some of the visitors did not know that money was required! It proved a great success, with straw-hatted chefs cutting the roast beef at the table and speeches from the top-table. This provided the one electronic breakdown of the meeting when the mike was positively coy, and Ted Longshaw gave us an unrehearsed "Danny Kaye" performance in his endeavours to communicate.

Formula Class

Champion: G. THIRANS B 67 laps		
2. Ruchat	CH	67 laps
3. Sabattini	I	67 laps
4. Olsen	S	66 laps
5. Collina	I	56 laps
6. Andexlinger	A	55 laps
7. Kruhsberg	S	32 laps
8. Strupler	CH	30 laps
9. Maringer	A	30 laps
10. Van Helden	NL	30 laps
11. Vincent	F	13/4 52 4
12. Denton	GB	13/4 53 6
13. Bernascone	I	13/4 53 6
14. Errington	GB	13/4 57 0
15. Seveso	I	13/4 58 9
16. Dognon	F	13/4 59 4
17. Fiocchi	CH	13/4 59 5
18. De Permentier	B	13/4 59 6
19. Blouet	F	13/4 59 7
Kuttner	D	13/4 59 7
21. Hassig	CH	12/4 25 5
22. Poulain	F	12/4 41 4
23. Preston	GB	12/4 42 6

Sports/Proto Class

Champion: D. MARTIN GB 931 laps (Official time 30.13.7)		
2. Bervoets	NL	92 laps
3. Preston Debbie	GB	91 laps
4. Ton	NL	88 laps
5. De Carro	S	78 laps
6. Greeno	GB	54 laps
7. Errington	GB	44 laps
8. White	GB	44 laps
9. Mares	I	44 laps
10. Wright	GB	43 laps
11. Plested	GB	14/4 40 9
12. Marani	I	14/4 43 4
13. Pagdin	GB	14/4 43 6
14. Angelin	F	14/4 44 9
15. Johansson	S	14/4 45 3
16. Booth	GB	14/4 45 7
17. Alberti	CH	14/4 46 3
18. Coosemans	B	14/4 47 0
19. Bartolomasi	I	14/4 47 9
20. Collina	I	14/4 50 2
21. Tassaux	B	14/4 50 8
22. Soderholm	S	14/4 50 9
23. Robkothén	D	14/4 52 7
24. Gustafsson	S	14/4 53 1

Keith Plested, Managing Director of P. B. Products, Havant, says:
"MacGregor & P. B. Products decided to combine their talents in order to develop a new two channel system for car racing.

The results were most impressive as it allowed an improved driving technique giving a distinct advantage under racing conditions."

A WINNING COMBINATION

The MacGregor MR 1222 ASN/2S special incorporating the new MR 12T high torque servo and the International from P.B. Products.

WORLD
500 mile
RECORD

4th. PLACE
COUPE DE MONDE, MONACO

1st. PLACE
ITALIAN GRAND PRIX

WORLD
24 HOUR
ENDURANCE
RECORD

1st. PLACE
SWISS GRAND PRIX

MR1222 ASN/2S
£109.50

Designed for the improved sensitivity and power necessary for controlling high performance models.

Available in all good model shops now.

MacGregor Radio Control

Canal Estate, Langley, Slough, Berkshire SL3 6EQ
Telephone: Slough 42251

STOP PRESS! To All Retailers: MacGregor are now distributors for P.B. Products

MacGregor
Digimac II
Transmitter
Type MR1222

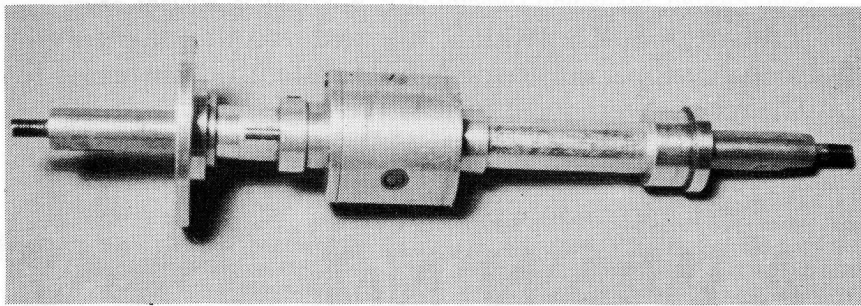

The very first AMPS diff — which had a remarkably short but instructive life.

SOMETHING DIFFERENTIAL

MORE BACKGROUND TO THE DEVELOPMENT OF MODEL DIFFS BY IAN ANGEW

PT3

THE AMPS diff has been in existence, on paper, for a few years. I've always wanted a model rally car to keep me occupied when not playing with the real thing. My design was excessively complicated, its spec ranged from a full 4-link trailing arm rear suspension to pneumatic shock absorbers — hardly surprising that I never built it! Apart from which, every time I had the drawings nearly completed I'd get another, better, idea and off we'd go again, the actual model building being put aside yet again.

Now the 'Blame' can be put at one man's feet — one Martin Samuel, who some of you will know. This time things just happened to be in the diff's favour. One evening, Martin was telling me about Mr. Booth who had fitted an American diff to his car and how easy it made the car to drive. Countless cups of coffee and a few sketches later I volunteered to make him one, little did I realise that I was about to build a monster!

PROTOTYPE 1

The next morning my father, brother and myself decided to make an AMPS diff as a special project. The next step was to get some basic dimensions within which to work. Unfortunately Martin hadn't assembled his car and we needed someone who had. Enter Phil Greeno who very kindly obliged — already eager to try the finished item.

We made all the parts during Christmas week ready for assembly after the holiday — a large boat order arrived from the continent — and we promptly put the diff back on the shelf until we had a 'quiet'

spell in February. The diff consisted of a centre ring assembly with much the same as we still use, but the half shaft tubes were not made from solid as they are now, but a comp-osite of Ali tube pushed into the centre ring end plates. The drive flange was also a press fit carrying halfshaft bearing in it. The halfshafts were 5/16 silver steel with brass sleeves on them to fit the wheels. All in all, a pretty flimsy affair (we had a lot to learn). The construction seemed strong enough but we did not realise just how much of a hammering a model car gets from the bumps and shunts that occur. The original diff lasted exactly two laps of Hackney before the drive flange worked loose and we lost drive. Back to the drawing board.

PROTOTYPE 2

This was very similar to our current production diff, only differing in two aspects. The drive flange was keyed to the diff housing by 1/16" drill blanks which also acted as the disc brake pins, and the half shafts were still the ones out of the first diff. In operation the halfshafts proved too soft and the disc wore very quickly on the pins but the housing proved good and strong. Phil, at this point, was still a bit undecided re the unit's advantages and felt perhaps that the casing was a little bit heavy.

PROTOTYPE 3

This was to be the basis of our production prototype batch of 20. It had the screw on flange, brake hexagon, lightened long end and plain halfshaft

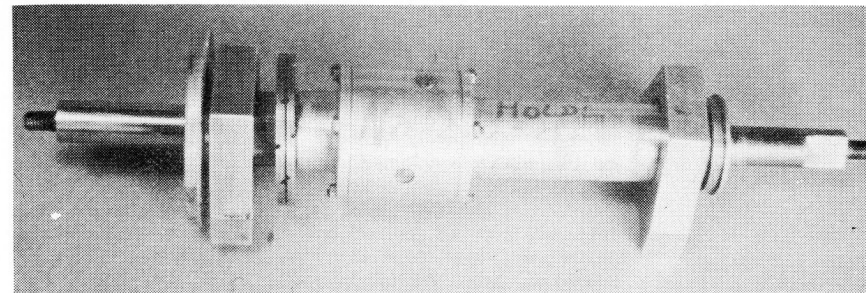

Next stage: drive flange keyed to the diff housing. . . future still uncertain. With slight mods. was used for 500 mile endurance run.

bearings. Its shafts were made from high carbon steel which, allied with the Thorp wheel which Phil was now using, seemed just strong enough. So the obvious answer was to harden them to increase the strength by around 15%. That seemed to cure the problem and so we went ahead with a small batch to see what other modellers could do with them. A few we took to the Monaco World Cup, which really started the ball rolling.

On our return, and for some weeks after, we spent most of our time talking to those who had the diffs and curing whatever problems they had. For a start the plain bearings were not standing up for a sufficient time, the halfshafts bent and the 8BA bolts holding the units together were stripping right, left and centre. The wear in the bearings was mainly due to the finish on the halfshaft which was cured at the same time we replaced the halfshafts with, this time, an alloy steel which again increased the strength by another 15%. The bolts problem was cured by putting studding right through. The problem of bending halfshafts was still there, but not to the same degree.

Just before Monaco I had a call from a certain Mr. Paul Padgin, asking if we could supply a diff for a 500 mile endurance record. Now, in view of the bearing

problem, we decided to revamp the second prototype which being all ball races would be the most reliable and could also be the best for a top class production unit. Which in fact is what we did.

In the first record attempt they bent a halfshaft but carried on with very little effect on the car's handling. That attempt was rained off after about 120 miles and the unit was returned to us for inspection. We then decided to get 'tough' and harden the halfshaft as much as possible. This gave us a further 40% increase in strength. Apart from that there was nothing else to be done, so we returned it and crossed our fingers. The unit, as we all read in the last issue, performed without problems. So, in total, that one diff has covered around 800 miles and on one inspection is probably good for the same again, only wear being behind the cross gears. So on the production unit we increased the bearing area by a factor of 22 to increase its life to a really trouble free long runner.

Just for interest sake, we reckon that up to the point that the first, all ball raced,

Beginning of the basic diff. Batch of twenty went to Monaco and set the whole project alight

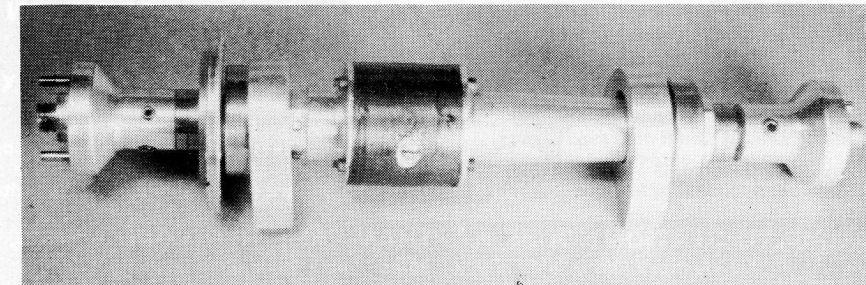

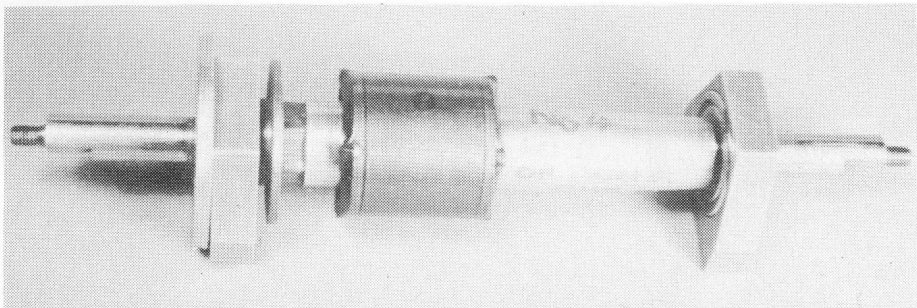

This is the Monaco diff.—with sundry toughening up the "production" model of today.

production unit was released we covered approximately 7,000 miles on test and to our knowledge in that time had the following failures:

- 1 bent 14 halfshafts.
- 2 Wore out 23 plain bearings.
- 3 Had 10 grubscrews come loose (and forgot to put 1 grubscrew in).
- 4 Stripped 18 bolts.

Since then only one little thing has reoccurred and that's the grubscrew in the halfshaft gear, on a few occasions, has

come loose. This has now been replaced by a larger grubscrew. As it happens this wasn't really necessary because the problem was in fact only due to the type we were using, which was a knurled cup point. After a while the knurl would crush allowing the gear a small amount of movement, which in turn allowed the grubscrew to hammer itself loose. The larger grubscrew is not detrimental and can only improve reliability.

Regarding special diffs; I still have nothing really to report but the signs are looking good and I will, when I have something concrete.



DIFFERENTIALS & ACCESSORIES

Now used by champions in

COMING NOVEMBER AMPS-SERPENT MK. III CAR

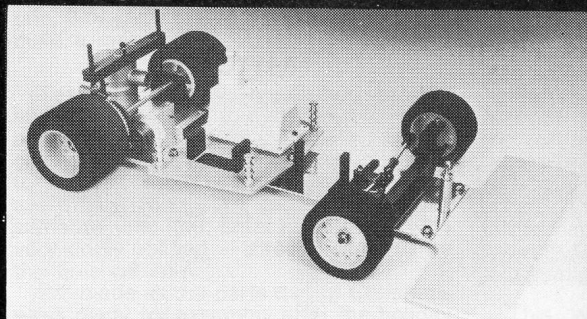

AMPS LTD. STATION HOUSE, HARTHAM LANE, HERTFORD, HERTS.
Tel. Hertford (0992) 56597. Telex Cables. Trade Enquiries Welcome

**FRANCE, HOLLAND,
 SWEDEN, GERMANY,
 ITALY, BELGIUM & OF
 COURSE, BRITAIN.
 WINNERS OF ITALIAN
 CHAMPIONSHIPS,
 SPANISH GRAND PRIX.**

**PB, Associated, and SG
 versions now in full production
 and available at your local
 model shop or for details write**

1978 UNITED STATES 1/8 NATIONAL ROAD CHAMPION

Art drove his Delta Super-J superbly in winning this most prestigious of USA Road Racing Championships. Art and his superb Super-J have now won all three major 1978 USA nationally attended championship races including the Winter-nationals Can-Am Road Race and the Indy 500 Oval Race. Art believes that the proven reliability and excellent handling of the Super-J chassis was a major factor in his impressive list of victories.

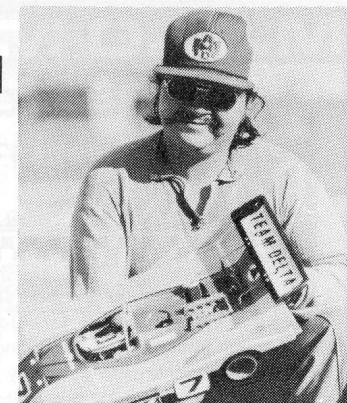

Art Carbonnel

Send \$1.00 (surface) or \$3.00 (airmail) for 1978 Illustrated Catalogue to Delta, address below, or



Delta Super-J

ENGLAND — Ted Longshaw, 80 Pepys Road, London SE 14. 01-639-5080.

BELGIUM — Cobra Racing, Chausee de Boondael 268, 1050 Bruxelles 02-648-78-67.

SWEDEN — Minicars, Bergsbrunnagatan 18, 753-23 Uppsala.

SWITZERLAND — Philip Rochat, Auf der Schanz 17, 4132 Muttenz.

**Contact
 your
 nearest
 European
 Delta Dealer**

WEST GERMANY — Spielwaren-Schmidt, 8230 Bad Reichenhall, Bahnhofstrasse 29½.

HONG KONG — Hobby World, 3 Yuen Ngai Street, Kowloon.

WEST GERMANY — Model Car Vertrieb, 6842 Burstadt/Ried, Nibelungenstrasse 81.

HOLLAND — Shamrock Raceways, Mathijs Heugenstr. 14 Maastricht.



DELTA IS CHAMPIONSHIP RACING MACHINERY

MICRO-MOLD FOR ALL THAT IS BEST IN R/C MODELLING

R/C ELECTRIC CARS

1/12th Scale



Regarded as just about the best 1/12 electric car kit. Includes one part moulded chassis plus tough underpan, Astro 05 motor, 6 cell Ever Ready rechargeable battery pack, really tough clear Lexan Body etc., etc.

Porsche 935 Turbo - Ferrari 312 - Formula 1
Imsa Monza G.T. - Chevron Formula 1
Camaro G.T. All Kits £51.89

Spares including bodies such as Ford Custom Van, Datsun 240Z, all in Lexan and with interiors. Price £7.49



Porsch 935 Turbo



MICRO-MOLD Products are available from all leading R/C hobby dealers

MICRO-MOLD

Station Road • East Preston • West Sussex • BN16 3AG

NEW 1/8 SCALE CLEAR LEXAN BODIES

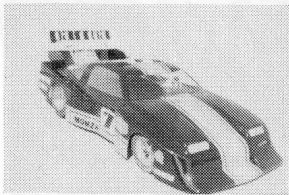

MONZA G.T.



TOYOTA

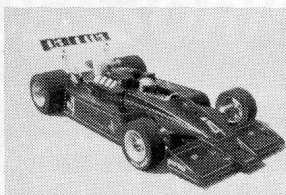

LOTUS F.1

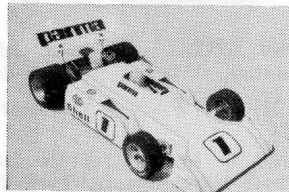

BANZAI SURTEES

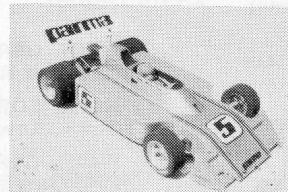

BANZAI PARNELLI

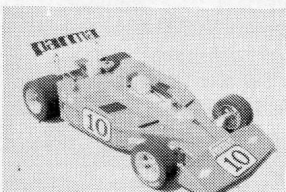

FERRARI F.1

parma

INTERNATIONAL INC.

13927 PROGRESS PARKWAY
NORTH ROYALTON, OHIO 44133 U.S.A.



INTRODUCTION TO CASTING

BY FRED LIVESEY

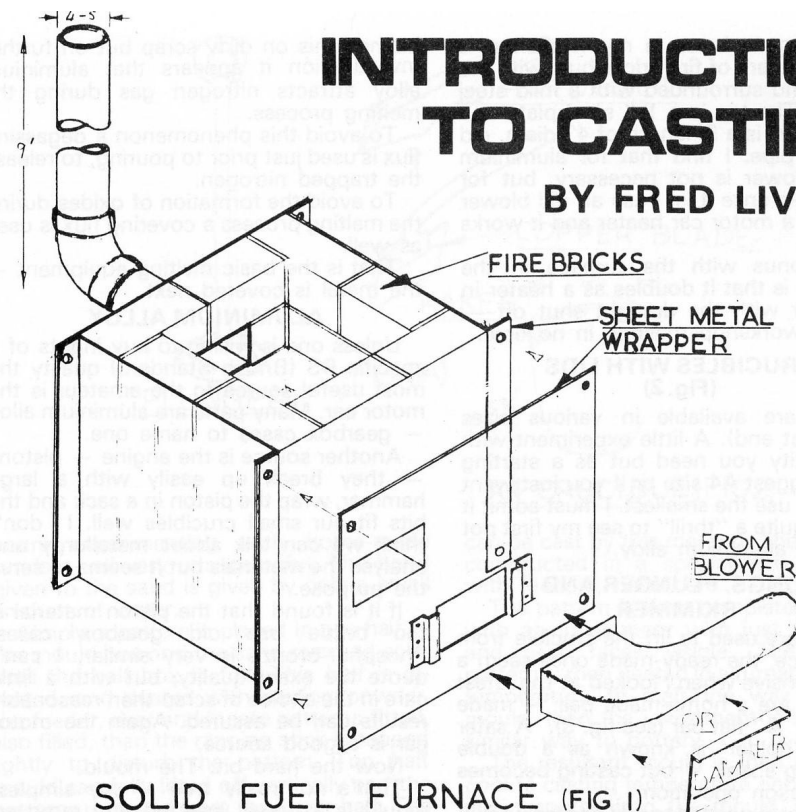

SOLID FUEL FURNACE (FIG 1)

WHY casting in a model car magazine you may ask.

Modellers carry out skills in a similar manner to full size counterparts but in miniature. Those of us who are lucky enough to have lathes, etc., find it necessary to widen our range of skills as we progress through modelling, and perhaps there are similar desires in others.

Some parts in model cars could well be cast, those that come to mind are Heat Sink Cylinder Heads, Front Steering Block, wheels, even engines and carburettor bodies — to name but a few.

What is casting? Simply the pouring of molten metal into a mould of heat resisting material. The metals used in model cars which may be cast by simple equipment are aluminium alloy, phosphor-bronze, and brass. The usual belief that the equipment required is expensive is not really true, a simple casting set up can be constructed for a reasonable cost, either in, or outside the workshop.

There are four types of casting open to the amateur and these listed according to the type of mould.

1. Green Sand Casting.

2. Shell moulding.
3. Lost Wax Casting.
4. Gravity Die Casting.

In this issue I aim to discuss the equipment common to them all, i.e., Furnace, crucibles, tongs, protective clothing, etc.

SAFETY

The need for utmost care in handling molten metals cannot be stressed enough. When you consider the metal will be anything from 600degC to 1200degC — then it is essential that protective clothing be worn. I suggest asbestos gloves (gauntlet type), good solid shoes or boots, an asbestos apron, and clear goggles. Before anyone jumps on me for being too safety conscious let me say — it's your body, protect it, if only to avoid the radiant heat. Accidents don't just happen they are caused.

THE FURNACE

My first furnace, believe it or not, was the open fire in the lounge. Using coke and with the blower up it rapidly heated a crucible of aluminium to casting temperature. (I must admit that I am blessed with a very very understanding wife!)

The furnace I use in my workshop is simply a square of fire bricks built with fire cement and surrounded with a mild steel wrapper. The top is a ½" steel plate and the chimney is a 9' length of 4" diam. old cast iron pipe. I find that for aluminium alloy a blower is not necessary, but for phosphor-bronze it is. I use an old blower unit from a motor car heater and it works very well.

One bonus with the furnace in the workshop is that it doubles as a heater in the winter with the draught shut off — gets the workshop roasting in no time.

CRUCIBLES WITH LIDS (Fig. 2)

These are available in various sizes (supplier at end). A little experiment with the quantity you need but as a starting point I suggest A4 size or if you just want to 'see' — use the smallest. I must admit it gave me quite a "thrill" to see my first pot of molten aluminium alloy.

TONGS, PLUNGER AND SKIMMER

Tongs are used to lift the crucible from the furnace, the ready-made ones seem a little expensive when I looked at the latest list. Mine are a home-made pair — made from 2" x ¼" flat bar (see fig. 3). A safer type of 'holder' is known as a double ended ring shank — but casting becomes a two person operation.

A plunger is needed to add degassing flux to the crucible (more later). The skimmer is simply a piece of wood used to scrape off the dross (oxides, etc., skin on surface of molten aluminium) — easily replaced.

FLUXES

Whilst not really equipment I think it may be best to cover them now. When I first started casting I always had a problem with porous castings in aluminium alloy. I

blamed this on dirty scrap but on further investigation it appears that aluminium alloy attracts nitrogen gas during the melting process.

To avoid this phenomenon a degassing flux is used just prior to pouring, to release the trapped nitrogen.

To avoid the formation of oxides during the melting process a covering flux is used as well.

That is the basic melting equipment — the metal is covered next.

ALUMINIUM ALLOY

Unless one is willing to buy ingots of a specific BS (British Standard) quality the most useful source to the amateur is the motor car. Many parts are aluminium alloy — gearbox cases to name one.

Another source is the engine — pistons — they break up easily with a large hammer, wrap the piston in a sack and the bits fit our small crucibles well. I don't think we can talk about metallurgy and analyse the materials but it seems to serve the purpose.

If it is found that the piston material is too brittle use old gearbox cases. Phosphor-bronze is very similar, I can't quote the exact quality, but with a little care in the choice of scrap then reasonable results can be assured. Again the motor car is a good source.

Now the hard bit. The mould.

That's not really true — my simplest mould is a dowel inserted and removed from the sand in the moulding box — the subsequent 'hole' is filled with molten aluminium alloy or phosphor-bronze and it produces nice round rods or sticks. Ingots are available in aluminium alloy LM4 from supplier (see end).

GREEN SAND MOULDING

The sand used is Mansfield sand (Supplier at end). I must say I spent many

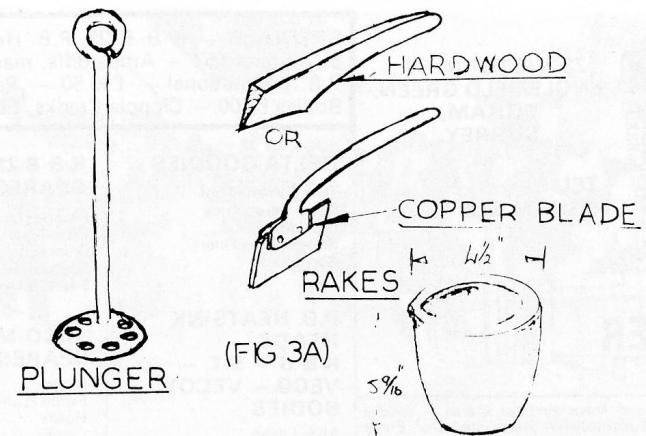
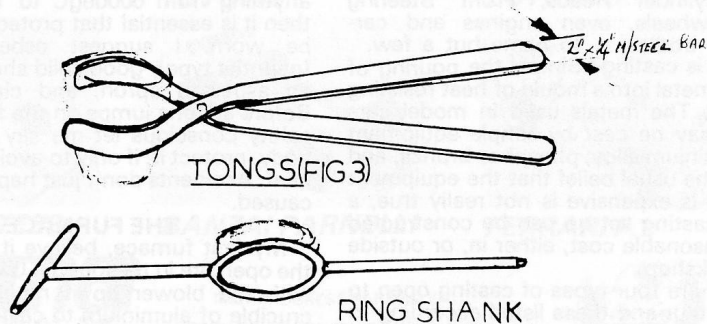

hours experimenting with home-made sands — all very unsuccessful. The bond given to the sand is given by only a small amount of water.

Simply, a pattern is placed in one half of the mould box and the sand rammed solid until the half box is full. This half is inverted, and dusted with parting powder, the feeder, riser and ingate patterns fitted, also filled, then the rapping stick is tapped lightly to disturb the pattern. Top half mould carefully lifted off vertically and the patterns removed from the lower half. The halves are placed together and weighted, then the molten metal poured until the mould is full. After a suitable interval for cooling, the boxes are pulled apart and sand shaken from the box — hopefully a successful casting.

SHELL MOULDING

Is used when more than one copy of the pattern is required, special moulding sand is used containing resins which, when heated, set to form a biscuit like material about ¼" thick. The two halves thus formed are then glued or clamped together and poured. The patterns need to be made from a heat resistant material as they are heated to 250degC before the sand is shaken over them to assist the setting or curing process.

The feeders, ingate and risers are fitted to the pattern and are formed direct in the shell.

The advantages afforded by shell moulding are the accuracy and finish which can be important in the finished casting.

LOST WAX CASTING

In some instances a very complicated casting i.e., cylinder liner with ports etc.,

can be cast by this method. The pattern is constructed in a special wax complete with feeders, risers, etc.

The pattern is then completely covered with an investment with just the feeder and riser faces visible. The invested pattern is then heated in a furnace first at a temperature to melt the wax from the mould, then the investment is baked in a similar way to pottery.

The resultant mould is then allowed to cool to casting temperature and the metal again poured into the mould. When the mould has cooled a certain amount, it is then placed in a container of cold water. The resultant steam developed bubbles off the investment which leaves the casting.

GRAVITY DIE CASTING

For more than one copy. The mould for this process is constructed from cast iron (works well with aluminium alloy). Suitable taper is provided for extraction of the casting — advantages are accuracy and finish and an improvement to the aluminium alloy metallurgical structure due to the process known as chill casting.

Just a little introduction to whet your appetite.

Part two will cover the moulding processes and some thoughts on pattern making.

Just an aside on safety — I saw a sign hung over a grindstone the other day which points out the importance of wearing goggles:—

You can eat with false teeth
You can walk with a wooden leg
But you can't see with a glass eye
Casting Material Supplier:

F. L. Hunt & Co. 48 Chapel Street, Salford. Manchester M3 7AA.

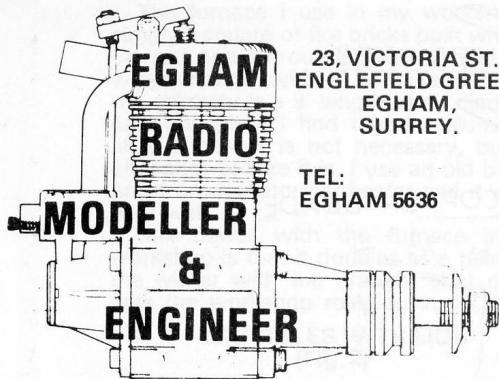

23, VICTORIA ST.,
ENGLEFIELD GREEN,
EGHAM,
SURREY.

TEL:
EGHAM 5636

Full Range of P.B. International and Associated car spares — special fuel mixed with Castrol 98 Gas Turbine Oil — Associated Disc Brake conversion for P.B. International

TYRES

P.B.	DELTA	ASSOCIATED
371, 372, 373, 542, 543 fronts 374, 540, 541 rears	340 A & B rears 316 & 315 fronts	832, 1223, 1225, 1226 fronts 2402, 2401 rears
UFRA Yellows fronts	ULTIMARA RSS 50 & 60 rears*	UFRA Slix & Specials rears

SPECIALS — K & B 21, P.B. Head, PERRY 61 Pumper £57 — Amps diffs, ready to go for P.B. International — £49.50 — Parma March Bodies £8.00 — Cippola Cranks, Get This 53p!!

DELTA GOODIES

Tank Quickfill Tops
Super Servo Arms
Override Kit
Sintered Fuel Filter
Servo Saver

P.B. HEATSINK HEADS K & B — S.T. — VECO — VECOY BODIES

ABS, Lexan
Lexan Paint & Glue

K & B 21 & S.T. X21 SPARES

Piston & Liners
Conn Rods
Crankes
Crankcases
Bearings (welded cage type)

VECO-McCOY SPARES

Rings
Piston & Liners
Heads
Crankes
Rods

CARBURETTORS

Perry 61 Pumper
E.D. Car
E.D. 60 Size
Thorp Slide
Webra Slide
O.P.S. Slide
P.B. Slide?

TANKS

Johnson Metal Tanks
Associated Fillers & Pressure caps
Associated Flip Tops
Big Shot Fuel Bulbs
Sullivan Crap Traps

OPEN MONDAY-SATURDAY (9.30 — 6.00)
LATE NIGHTS MONDAY & FRIDAY (8.00)

**ACCESS, CHEQUES
EVEN CASH!**

*** EASY PARKING ***

GB MODELS

9 THORNBURY ROAD,
UPHILL,
WESTON-SUPER-MARE,
BS23 4YE.

WESTON-SUPER-MARE 26265 (P.M.)

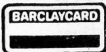

Ring Through Your Access or Barclaycard Number for Fast Mail
Order Service on all R/C Car Requirements

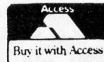

FULL RANGE OF P.B. KITS AND ACCESSORIES IN STOCK

PB DIFFERENTIAL : NEW AIR FILTERS : GRP CHASSIS PLATES available NOW
NEW CARBS available shortly

International Kit **£75** — Expert Comp **£61** — Expert Std **£45** — Racing Doubles **£29** — MRP 1/12th
Electrics from **£59.95** — Mardave 1/8th **£23.75** — Mardave 1/12th — Electric **£37.50** — New S.G.
Futura III Kit **£72.00** inc. Free ABS Body — Your Choice — Full Range of Raydio & P.B. Tyres —
K & B, S.T. OPS and Veco Engines

Special Purchase of 1/12' Tyres, 1 3/4" diam., 1 1/8" Bore
All Grades 32p to 40p per pair + postage

Join Woodspring Radio Auto Club and Drive at Mendip Model Racing Circuit

**WE ARE DISTRIBUTORS FOR P.B. PRODUCTS AND
RAYDIO TYRES — TRADE ENQUIRIES WELCOME**



FIESTA STOX AT WORTHING

FOLLOWING weeks of organising by the Worthing based Southern Radio-Car Club, many of the country's leading model superstox drivers converged on the Raceway, that nestles at the foot of the beautiful Sussex South Downs, on what was to be one of those all too rare glorious 1978 summer days.

Included in the lineup of 34 entrants were World Champion Dave Wragg, twice ex-World Champion Steve Talbot, both from Leicester; current National Championship Points leader Roger Bye from the Chessington Club and members of the Haywards Heath and Southern Club.

With signing-on, scrutineering and practice complete, the first event began promptly at 11 o'clock with Steve Talbot, in his immaculate silver and blue car No. 8, opening his account with a big 36 laps in the 4 minute race. Event 3 saw Champion Dave Wragg, No. 306 answer with a blistering 40 laps in his equally superbly prepared Kavan/Veco stox, and in fact nobody was to better this during the entire meeting. Indeed it was becoming apparent that the experienced Leicester drivers were dominating the first Heat, seeming to adapt more quickly than the other visitors to the fast Worthing track.

The first of the six events making up the second Heat began with Leicester's John Orton, No. 435, completing a neat 38 laps to give him a total of 75. Dave Wragg replied with 37 (Total 77), while Steve Talbot improved further with 39 (Total 75). National leader Roger Bye, who had

Start of the final at the Fiesta Meeting. Some of the good crowd in attendance can be seen in the background.
A Tod Toombs Photo.

begun with a poor 29 also improved, and stood at 67 laps after two races. Southern member George Short, No. 46, in his CIS Insurance sponsored stox completed a creditable 32 laps despite only having first held a transmitter some six months earlier!

By now, a crowd of 5-600 had gathered by the track, no doubt attracted by the pre-race publicity in the press and on local TV and radio. Basking in deckchairs, and enjoying ice cold lagers from the Sussex Yeoman bars, the SRCC were presenting a race meeting to remember, with an excellent and inexpensive race programme available and a first class commentary adding to the enjoyment.

The third Heat promised much, with many drivers separated by very narrow margins. Stu Busby, No. 85, another Leicester driver who had travelled down overnight scored a healthy 36 laps, but his poor earlier showing had excluded him from any chance of reaching the Semi-Finals. Dennis Mansell, No. 182, improved with 34 laps, while Chessington's Adrian Garrett showed absolute consistency with his third 35 lap event of the day.

With the 3 Heats completed, the top placed 12 drivers went forward into 2 five minute Semi-Finals. Club interest was fairly evenly divided with 4 each from the Leicester, Chessington and host Southern

Club through, with best placed Haywards Heath member Terry Crawford just failing to qualify.

Semi-Final 1 saw a close race between Dave Wragg and Steve Talbot who totalled 49 and 46 respectively. Southern Associate Member Norman Spiller No. 26 managed a fat 43 laps.

The second Semi had Leicester Secretary John Orton on 42, Roger Bye on 41 and Steve Richardson, who had given a magnificent display all day, complete a 39 lapper.

Race Director Alan Barton awaited the arrival of Worthing Beauty Queen Michelle Slaughter, who had agreed to present the winners, awards, and at a little after 2.30 the cars were called round to the start line. A thumbs up from Alan, and six of the best drivers in Britain were away in the 5 minute Grand Final.

Into the lead from the start went the dark blue car of Roger Bye, followed closely by Dave Wragg, Steve Talbot, John Orton, Norman Spiller and Steve Richardson in that order. Slowly, very slowly, Dave Wragg and Steve closed the gap on Roger's car, with Steve trying desperately hard to move into second place — in fact, after two minutes he made a passing move, and Dave shut the door at the top bend, sending both cars into a locked roll over. Steve's car cut out, and the World Champion also lost valuable time while the marshals struggled to untangle the cars, allowing John and Norman through into 2nd and 3rd places. However, Dave rejoined and put on the

drive of his life, but his luck seemed to be out, for he tangled with a back marker, resulting in his car performing a triple and over end somersault into the hands of a marshal. Meanwhile, Steve had restarted and was back on the track, but the car had suffered in its encounter earlier and had visually lost a lot of the edge it had been displaying.

Unflustered, young Roger Bye plugged on, sensibly keeping out of trouble, and it is to his credit that during the whole of the Final he did not once have to take his stox off the track such was his skill and meticulous model preparation. As the siren blew for the finish, the spectators broke into spontaneous applause, such had been the excitement of the event.

The result was announced as follows:

- 1st Roger Bye (258) 48 laps.
- 2nd Dave Wragg (306) 43 laps.
- 3rd John Orton (435) 41 laps.
- 4th Norman Spiller (26) 32 laps.
- 5th Steve Richardson (55) 29 laps.
- 6th Steve Talbot (8) 27 laps.

With Roger being presented with the winner's prize of a £50 car radio, kindly donated by sponsors Searle of Worthing, the meeting drew to a close. Although only in its first year of existence, the Southern Club must be congratulated for putting on this outstanding meeting. Arrangements are now under way for the South of England Championships to be held in Worthing on the August Bank Holiday Sunday in 1979 — a definite must for every enthusiasts' diary.



To the Winners the Spoils!

Michelle Slaughter, Worthing's Fiesta Beauty Queen poses with the winners after prizegiving. Left to right: Dave Wragg (2nd), John Orton (3rd), Miss Fiesta and Roger Bye (1st).

A Tod Toombs Photo.

HOBBY WORLD

WE STOCK THE BEST CAR KITS, RADIO, ENGINES AND ACCESORIES FOR R/C CARS

3 YUEN NGAI ST. KOWLOON HONG KONG

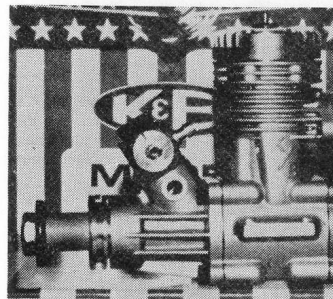

K & B 21

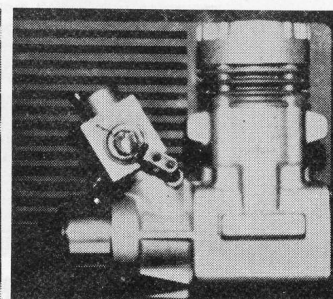

HGK 21 SF R/C

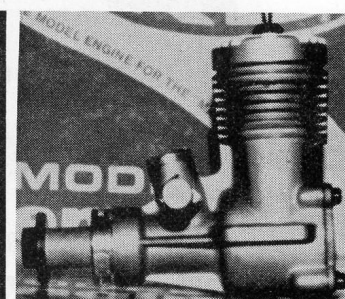

VECO 19

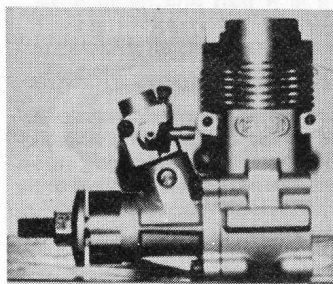

FUJI 21

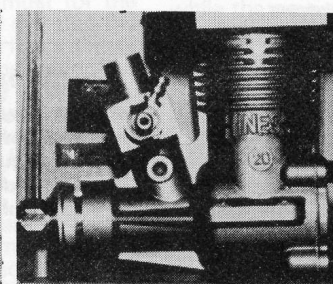

HINNESS 20BB

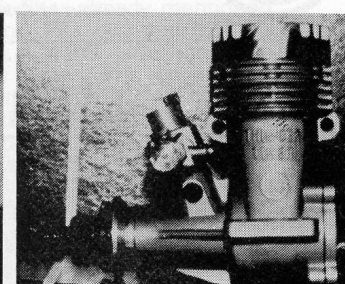

THUNDER TIGER

ENGINES

K & B 21	£40.00
K & B 21 McCoy	£53.50
VECO 19	£20.00
Veco 19 RC	£23.00
Veco 19 McCoy	£40.00
Veco 21 McCoy	£40.00
Ops 21	£39.50
Supertigre X21	£44.50
Webra 20	£42.00
HGK 21	£33.00
Hiness 20	£32.50
Fuji 21	£25.50
Enya X19	£30.00
Thunder Tiger	£10.00

CAR KITS

AKS 78 special	£70.00
Associated RC100	£80.00
Associated RC200	£100.00
Challenger	£75.00
Delta JL770	£80.00
Izumi	£68.00
Marker	£115.00
MRP	£72.00
Super Dash	£65.00

SOLE DISTRIBUTOR:

SUPER ENAMEL — 70p specially for clear LEXAN and BUTRATE bodies.
Z.90.6 LUBRICANT — 65p excellent for bearings and bushes.
SIMICHROME POLISH— £2.00 Clean and chrome all kinds of metal.

ACCESSORIES & PARTS AVAILABLE

AKS — Associated — Delta — Globee — McCoy — MRP
 Perry — RPM — Tatone
 RADIO — Futaba — Logita — Sanwa — K.O.

TRADE INVITED MAIL ORDER ACCEPTED

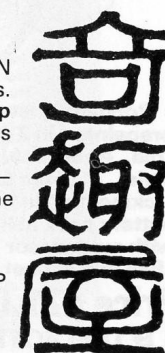

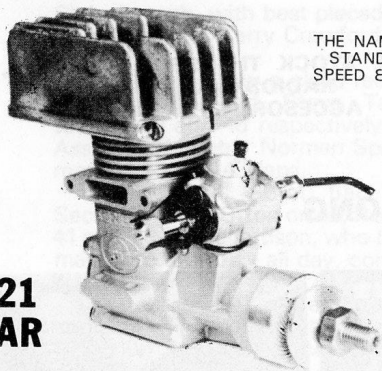

THE NAME THAT
STANDS FOR
SPEED & POWER

SUPER Tigre

Since its arrival last year the Super Tigre X21 has been the pacesetter for other manufacturers to follow. A rugged construction able to cope with the arduous conditions of competitive car racing. Just compare the specification with the opposition. An ABC piston assembly with light-weight piston, bronze bushed bigend conrod, heavy duty 12mm dia. crankshaft running in double ball bearings, specially diecast crankcase not a conversion from aircraft motor, large bore carburettor with the superb idling of all MAG series carburettors, deep finned heat sink, squish band head. BHP .75 at 25,000 rpm, weight 9 1/4 oz. Used by most of Europe's leading drivers.

Race-proven to be one of the most reliable motors produced so far. It's the motor that finishes that counts. The long life of all Super Tigres together with easy availability of any spare part for that eventual day when its run "over the hill" makes this motor the popular choice. No Labour Charges on ST repairs: you only pay for parts and postage.

**X21
CAR**

£48.91 (inc VAT)

complete with heat sink

SUPER TIGRE MOTORS ARE AVAILABLE FROM THE VERY BEST MODEL SHOPS



WORLD ENGINES

LIMITED

97 Tudor Avenue, Watford, Herts. Phone Watford 42859

Visitors by Appointment

S.A.E. with enquiries please

Spectron

**The 1/12 car
for the
serious
racer**

- Polycarbonate Body, pre-painted in 2 colours (Porsche, Lola, Abarth, Alfa, Can-Am and Indy style)
- Close tolerance Rear Axle assembly
- Self-locking nuts in front suspension and linkages
- Welded battery pack in heatshrunk sleeving
- Motor RS54 with suppressor
- Ackermann steering and servo saver
- Ball and socket linkages

Price £71.00 + VAT £76.68

Send cheque or postal order to:

(Trade enquiries welcomed)

I & D ELECTRONIC CO. 46 Church Road, Bames, London SW13, England Tel. 01-741 0333.

Competitive features include:

- **Mark II Smoothtronic electronic controller with proportional speed/dynamic braking and built-in regulator for RX and steering servo**
- **Polycarbonate Chassis 3mm thick**
- **Polypropylene Front Bumper 3mm thick for maximum protection**

SHOPPING AROUND

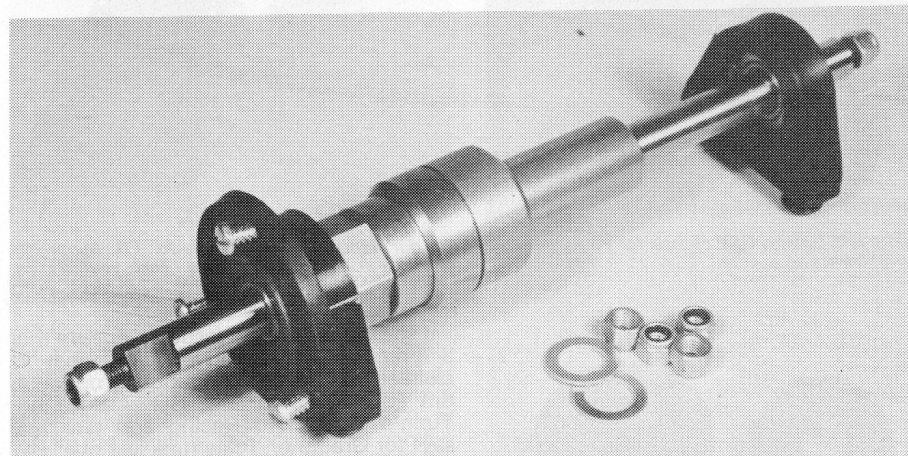

AFTER weeks of frustrating delay in the Customs, a splendid parcel of goodies has arrived from those nice Delta people. It includes a complete Super-J kit, which is so different from the one I made up an issue or so ago that it is a must for the Spring. In the meantime I will mention the slide valve carburettor, which has a simple flat shoe automatically compensating for any wear, thus ensuring long reliable life. This goes with the latest Delta tank as mentioned in our earlier write-up — but this again is different with a fine array of pipework on the outside. Of unusual interest is the treatment of the clutch unit. The flywheel is split and clamps to the engine shaft giving the same result as when running with a tapered collet but with much less difficulty. Bill Campbell writes: "The Red Rulon clutch shoes have proved to be troublefree over a full season and we do not even use a spring now as it has proved unnecessary when used with a 'drag brake' as the small amount of brake holds the car at idle with no noticeable effect on the engine. The Rulon runs on a steel bellhousing and the entire clutch is as bullet proof as our wildest hopes."

Which naturally leads to that other eagerly awaited slide valve carb currently on the stocks at PB Products. Keith tells me he has just got delivery of a computerised miller at vast expense which will mill out the main components from the solid in next to no time rather than make

It's here! The PB diff. is on the run! Lowest priced yet: get while you may in its attractive orange anodised livery.

up a fabricated job. It should be along by the end of the year if not sooner. Meanwhile the new air filter already mentioned is in full production. The recent visit of the PB trio — KP, TL and PG — to Barcelona to carry off the Grand Prix gave them ample opportunity to test its worth in the sandy area round there which has not yet been seeded. It really paid to keep on the island! Finally, the PB diff is now in quantity production. "When the box labels turned up, I really felt it was there!" enthused Keith.

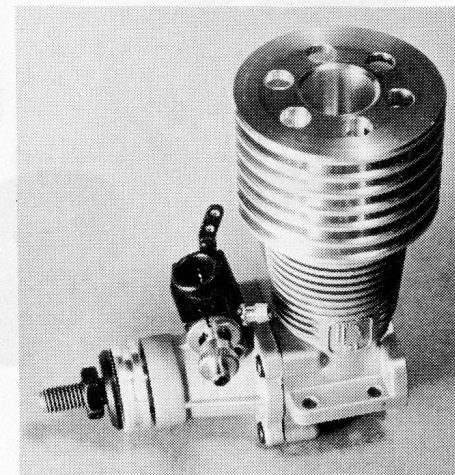

HB21 from Helmut Bernhardt, primarily designed for Graupner's cars. Irvine are distributing. Heatsink is included.

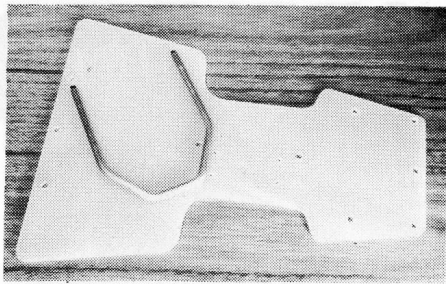

On our left: Greeno GRP chassis for PB with rollbar also shown.

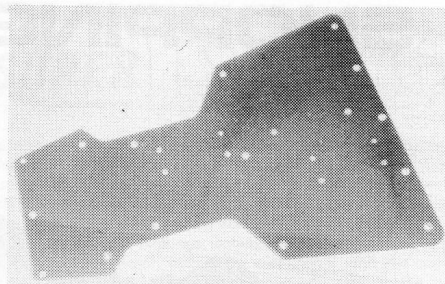

On our right: PB GRP chassis for PB. Minor differences in cutout and drilling. Take your choice.

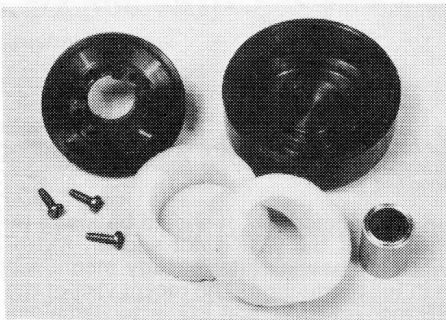

Not to be hidden: innards of PB air filter which really does keep out the finest dirt. Below: Delta flywheel — now split — and clutch unit.

I see in the October issue of *Adepte* that a French firm is advertising what is claimed as "the first French production diff" adaptable for PB, SG, Associated, Turin's Car, Micro Racing and (so they say) for Graupner. Price runs just over £41 in French francs. The Graupner car has yet to appear over here offered in France. I understand that it will not be on sale until a proper English translation is available of the building and running instructions. This is a task currently undertaken by German feature writer Erich Rabe, who will I believe be editing a new German model magazine shortly to be launched in a very big way.

Exciting news from Irvine Engines. From December they will be marketing the Associated i.c. 1/8th kits specially boxed

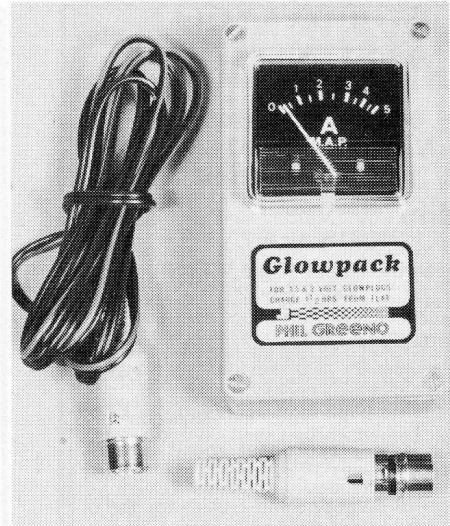
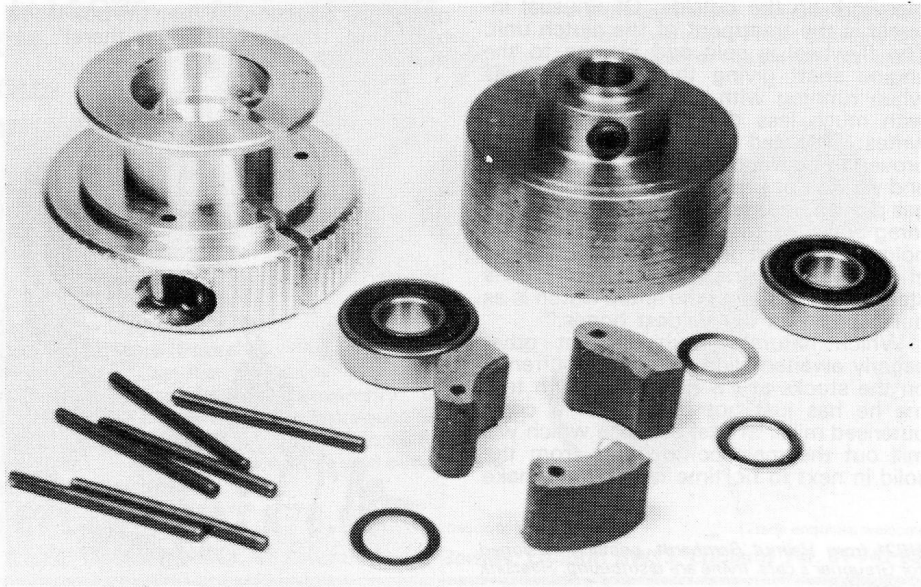

Delta fuel tank — "and the music comes out here." Beautifully made.

for the European market and complete with bodysells, either Formula or Sports/GT to choice. This has meant a slight adjustment of prices with RC1 at £56.95 (no variants as bodysell to choice) RC100 at £79.95 and RC200 at £119.95.

Jerobee are now making a 1.2 volt reverse conversion for their electronic speed control units. It can easily be fitted or removed to save weight. However, it also requires a pushbutton modification to the Transmitter. This again is straightforward and does not affect normal use of the transmitter. No price quoted.

I have also just received an example of the latest HB21 r/c car engine which Irvine Engines are distributing. This was developed primarily for the new Graupner car but should be an excellent workhorse across the board. It is provided with its own integral heatsink, which not only looks very neat and workmanlike but also is one less item to buy. Another news flash is that the Dutch Serpent car should soon be available in this country (November is the promised date, so maybe already) and will be distributed by AMPS Ltd. of Hertford. A kit has been promised and when it comes along will be made up and duly reviewed. Peter Bervoets' car ran very well at the Euro Champs in the summer and enjoyed the first of the modified diffs for the Serpent. Apart from those seen in use at Lilford Park the very latest Super Tigre has yet to make its bow. It is a formidable tough looking version, and allied to the new SG diff has been performing well in the hands of the Sabbatini Italian team members not forgetting also Ronny Ton in Holland.

Flash news! Bob Rosser is now in the shop with Phil Greeno: Jeff Page moves over to workshop to make the goodies. Expect quite a lot of exciting "Greeno Specials" shortly. Dare we mention there is also a fine new Porsche . . .

A Greeno special — latest Glowpack now on offer from Rayners Lane. And below the Greeno Field Charger. Charge up on the car battery on the way to the meeting

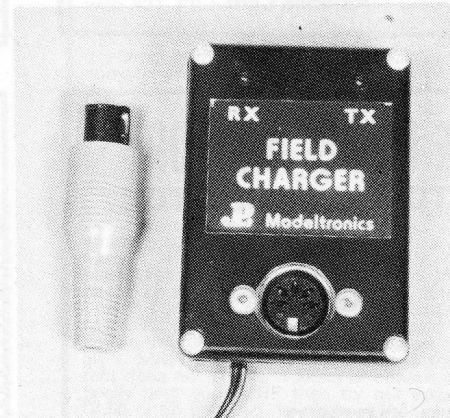

Delta slide carb — a natural for that fuel tank above.

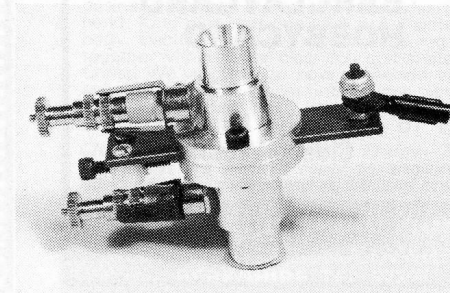

MICHAEL'S MODELS

646-648 High Road,
N. Finchley, N12 0NL
Telephone: 01-445-6531

CAR KITS by Mardave, P.B., Ke'Jon, Lectricar.

ENGINES by Super Tigre, O.P.S., K&B, Veco, Enya.

P.B. International Kit **£75.00**

K&B 21 R/C **£47.50**

P.B. Heatsink head for K&B, Veco **£7.50**

Lectricar with proportional speed control, Porsche 911, Escort, Porsche 936 **£44.87**

Full range of spares. Send S.A.E. for list of Kits, Engines.

Phone your Credit Card Number for same day service. Access, Barclaycard, Carte Bleu, Eurocard, Mastercharge, Visa, Bank America Card

FULL SIZE PLANS

Of a 1/8 scale stock car as featured in this magazine. These are fully dimensioned engineering drawings for the metal working model maker. For 10 sheets of drawing 22 1/2" x 16 1/2" plus stock list

Send **£5** (post included) to:

A. HOBBS

27 HOLLON COURT,

REDHILL, SURREY.

TEL. 62190

THE MODEL AIR-PORT FILTON BRISTOL

**R/C CARS
ENGINES
RADIO**

**MAIL ORDER
ACCESS
BARCLAYCARD
HOBBYCARD**

EXIT 16 — M5 Five Minutes
Closed Wednesday

134 GLOUCESTER ROAD NORTH
FILTON, BRISTOL TEL: 694541

BILL GORDON (MODELS)

2 TOWER COURT, DUNSTON,
GATESHEAD.
Tel: 0632-605545. TYNE & WEAR
THE NORTH EAST RC CAR CENTRE

MARDAVE CAR KITS

FIRENZA	LOLA	£23.75
CAPRI	HESKETH	
McLAREN	STOCK CAR	

PB Expert Standard kit	£45.00
PB Expert International	£75.00
SG Futura	£69.00

ELECTRIC CAR KITS

Mardave BRM	£37.50
Lectricar Porsche 911	£44.87
Sanwa Porsche 935 (inc. 2 chan Radio Gear)	£59.95

MOTORS:

VECO 19 car	FUJI 19 BB	S.T. X21	OPS 3.5
VECO 21 Car	CIPOLLA 21	K.B. 3.5	IRVINE 20

2 CHAN RADIO:

New Power Max, 2 only	MacGregor 2	£67.00
£59.95	Digiace V2	£73.00
Sanwa Mini 2	Medallion 2	£72.50

S.A.E. for leaflet with further information and prices.

Postage Kits £1.00
Accessories 40p

Open Mon. to Sat. 9-5.30.
Late Night Thurs. 7.00 Closed Wed.
FREE PARKING

PHIL GREENO MODELS LIMITED

9 VILLAGE WAY EAST, RAYNERS LANE,
HARROW, MIDDX.

GLOW PACK

Pocketable power source for 1 1/2 and 2v glowplugs, charged directly from 12v accu. (or car battery while driving)

Price £14.95

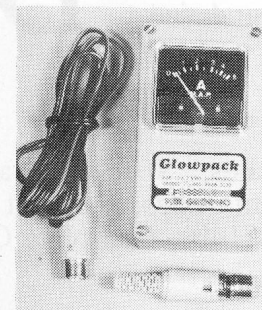



FIELD CHARGER

Charges Tx and/or Rx from 12v accu. or car battery when no mains supply available. (Car can be running)

Price £7.95

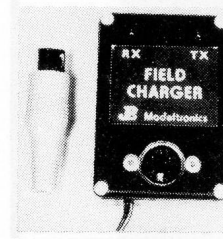
Trade Enquiries Welcome





Isn't the Best worth just a few more Quid, Marks, Gulden, francs, Dollars, Lira, etc????

Thinking Electric Think Bo Link!!

Available in Europe

Write for name of nearest distributor
Catalogue available: Send £1 for postage

Bo Link Industries

Box 80653 — ATALANTA,
GEORGIA 30366 U.S.A.

MRM FOR CARS

"Making a start in R/C cars? Then if you are reading this mag that's a good first step. The next one is to make tracks to a genuine car specialist (preferably us but that is by no means essential) where you should be able to see cars and goodies in their various forms and receive practical advice on assembly, setting up and so on, based on somewhat more experience than putting the box on the shelf. Our recent tasks of sorting out disasters and hearing of the experience of people in the hands of "TOY" shops leads us to seriously doubt the dubious honour of being a member of the model trade. Enough of the serious stuff, this business is meant to be fun but if you'd like to come and chat cars and fiddle with our goodies (the stock duckie, the stock) then you're most welcome. Especially the disgruntled soul who wrote to the last 'ish'. He complained about the cost of bits but if anyone can produce them cheaper than PB then we'd like to know and as to "probably not stocking them" he'll be well pleased. We've got more PB spares than one wholesaler we know. By now some of you clever chaps will have realised that this is an ad. so here goes with the rest of the spiel. As well as the usual Internationals at £75 plus a few ready built for no extra but only one body. Export versions at £66.10. Juniors at £35.67, no tank but we'll give you one free! Associated from £25 to £80. Plenty KB 21's growing in the boxes at £39.95 and X21's at £44.50 are still refusing to wear out so we've plenty of spares. OPS at £42.75 or 1000% more reliable than once upon a time. We have a non-repeatable special on SG Competition cars with X21 fitted and an ABS F1 body ready to go at £95 cash (that's £20 off). Couple of used vehicles — £110 buys an Intl. with X21, PB head, Pumper, Delta links, Johnson flip-top, Parma March F1, one 17M, 832's and Uffra Slix. One owner 'S' reg. or for £80 a re-worked KB gobbling, pumpered X21 in an Intl. rear half with epoxy chassis joined to plain bearing front end ('S' reg.). Try an MRM tank at £7.50, lacky bands for holding down the flip-top are neither supplied nor necessary. 12th scale now, we need the room so another genuine clearance offer of 20% — yes 20% off SPEEDBUILT LAMBORGHINI & FERRARI kits for 09's, e.g., OS 10, Fuji 09, Enya 09 and any two function radio giving forward and reverse speed by a clever little gearbox, plus independent suspension, pre-coloured carbonate bodies. The most amazing sales success story so far has been the Tamiya XR 311 fighting vehicle. We don't sell plastic kits but we make no excuses for this one; it has to be seen to be believed — £44. 1/8th Electric Porsch Turbo £49, she's big, but we mean really big. Mardave, of course, is always here and if you're having trouble getting spares, its 'cos we've gottem all + MRP, BoLink (but here we have the chassis that does not break). Talking of chassis, if you've finally bent your MRP then try our epoxy job at £2.50 or £2 undrilled, its cheaper than the original and will transform a Mardave. New Associated electric arriving; not cheap but its got to be good. The best is yet to come... SPECTRON by a manufacturer not unknown in electric racing. Has desirable features as non-slop rear axles that don't bend. King pins that don't fall out. Painted Lexan body. Electronic gas-tap with voltage reg. All held together with a crystal clear poly carbonate chassis. Christ! We've gotta go now, Spectron will be on our shelves before we've finished our own car but more about that next 'ish. Now where's that sodding chuck key...

Closed Thursday, late night Friday—7.00 p.m.
Sorry but we cannot reply to enquiries that don't enclose a stamped addressed envelope."

MAIDENHEAD RADIO MODELS

55 QUEEN STREET, MAIDENHEAD,
BERKSHIRE. TEL. 37295

A Specialist Service for the Car Builder

Components made to your sketches or our design.

DHI

Machine Cut Gears, Differentials, Special Glass Fibre Chassis Alloy Wheels, Alloy Front Axles, Exhaust Systems, Tyres Precision Ground on your Hubs, Complete Cars built to your design or Specification.

D.H.I. ENGINEERING CO.
1-8 HORSE YARD, ESSEX ROAD,
LONDON N.1
01-226-2511

ANGLOGRAPHIC

Produce Design Graphics in all their varied forms:



Club and Company Logos,



Promotional garments: Sweat shirts, T shirts, Team Racing Overalls, Badges, Stickers, Hats, Bags etc.



All packaging, Sales Display material, Leaflets, Brochures, Photography.



Phone or write now for more details:
01-907 7074
182 Uppingham Ave
Stanmore, Middlesex.

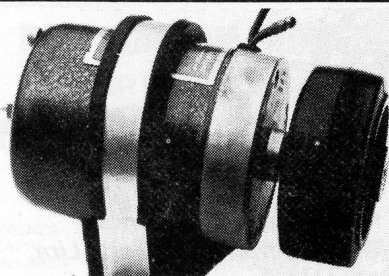

AT LAST — A PURPOSE MADE CAR STARTER

3" dia. x 6" long — supplied with 3" wheel for surface mounting or 4" for box mounting (please state which) **£18 + £1.30 p & p** or **£16** to callers — (Yes! **£16**)
Trade enquiries welcome

Egham Radio Modeller & Engineer, 23
Victoria St., Englefield Green, Egham,
Surrey. Tel: Egham 5636.

HB21 PDP Car

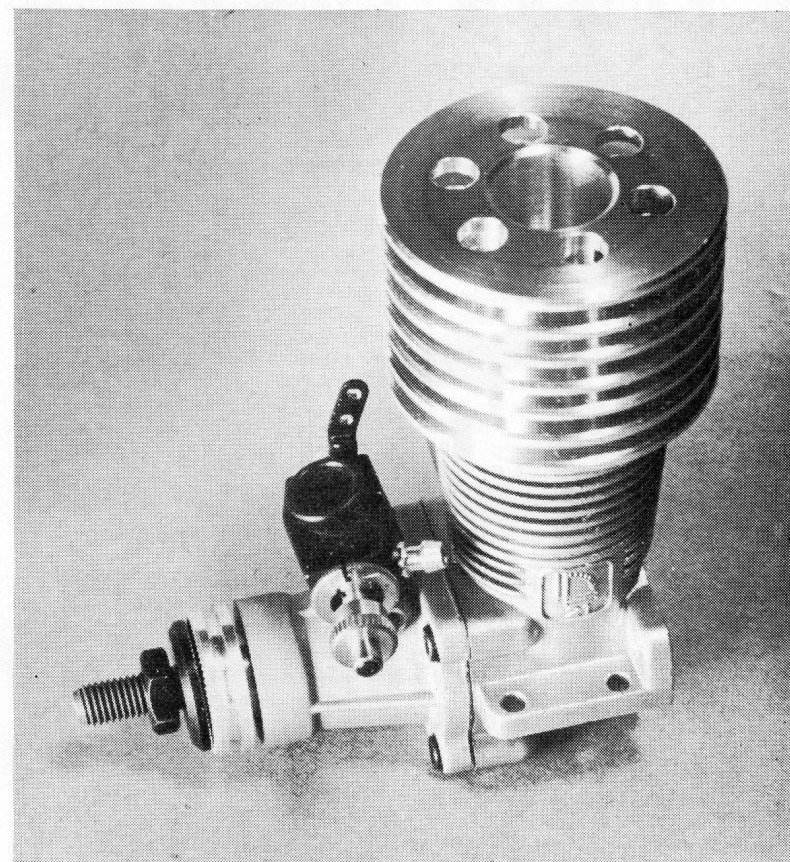

THIS NEW ENGINE FROM HB HAS BEEN SPECIALLY DEVELOPED TO MEET THE REQUIREMENTS OF MODERN R/C RACING

SPECIAL FEATURES * Perry directional porting provides exceptional power and flexibility * Ringed piston for long life * New design front plate of extremely robust construction * Cap-head screws used throughout * Heatsink head

Price £34.95



IRVINE

Irvine Engines,
Unit 8, Alston Works, Alston Road,
High Barnet, Herts. Tel: 01-440 0923



INTERNATIONAL

PB7 Basic Pack



"LET IT SPEAK FOR ITSELF"

1st PLACES IN 1978

Coupe Du Monde — Monaco
 European Championships — Lilford Park
 Belgian G.P. — Nivelles
 Italian G.P. — Modena
 French G.P. — Toulon
 German G.P. — Friederichshafen
 British G.P. — Lilford
 Welsh G.P. — Wrexham
 Swiss G.P. — Geneva
 Spanish G.P. — Barcelona
 British National Champs. — Wombwell
 South of England Champs. — Mendip

National Opening Meeting — Wombwell
 National Open Meeting — Bournemouth
 National Open Meeting — Bradford
 National Open Meeting — Tibshelf
 National Open Meeting — Newbridge
 National Open Meeting — Catfoss
 Dutch 3 hour — Heemstede
 New 24hr World Endurance Record
 New 500 mile WORLD distance record

PB7 (Illustrated) Basic Kit **£66.10**
 PB6 With two chassis, two bodies, two wings, two bumpers and fuel tank. **£75.00**

NEW ITEMS

Part No. 550 Differential rear axle complete with enlarged disc brake and bearing blocks
 — truly race proven. **£34.00**
 Part No. 555 New flip top 125cc fuel tank **£4.50**
 Part No. 565 New shielded air filter complete with universal adaptor sleeve and spare
 element **£2.75**

P.B. Products, Downley Road, Havant, Hants. Tel: (0705) 471774